

KTM POWERPARTS **INFORMATION**

HEATED GRIPS



60712964044

05.2017
3.213.596



KTM Sportmotorcycle GmbH
5230 Mattighofen, Austria
www.ktm.com



3 DEUTSCH

Wir freuen uns, dass Sie sich für dieses Produkt entschieden haben.

Unser hochwertiges Qualitätsprodukt ist rennerprobt und wurde speziell für sportliche Herausforderungen entwickelt. Eine korrekte Montage des Produktes ist unerlässlich, um ein Maximum an Sicherheit und Funktionalität gewährleisten zu können. Bitte befolgen Sie daher die Montageanleitung oder wenden Sie sich an Ihren autorisierten Fachhändler.

Für falsche Montage oder Verwendung dieses Produktes kann der (Quasi-)Hersteller bzw. Lieferant nicht zur Verantwortung gezogen werden.
Vielen Dank.

11 ENGLISH

Thank you for choosing this product.

Our high quality product has been tested under racing conditions and was developed specifically for use in sports activities. Correct installation of the product is essential to ensure that a maximum degree of safety and functionality is achieved. Therefore, please follow the installation instructions or contact your authorized dealer.

The (quasi) manufacturer or supplier cannot be held responsible for products that are incorrectly mounted or inappropriately used.
Thank you.

19 ITALIANO

Grazie per aver scelto questo prodotto.

Questo nostro prodotto di pregiata qualità è collaudato nelle competizioni ed è stato sviluppato specificamente per gare sportive. Il montaggio corretto del prodotto è fondamentale per garantirne la massima sicurezza e funzionalità. Rispetti quindi le istruzioni di montaggio o rivolgerti al proprio concessionario autorizzato.

Il produttore (detentore del marchio)/fornitore non può essere considerato responsabile per un montaggio o impiego errato del presente prodotto.
Vi ringraziamo per l'attenzione!

27 FRANÇAIS

Merci d'avoir porté votre choix sur ce produit.

Notre produit de haute qualité est éprouvé pour les compétitions et a été conçu spécialement pour un usage sportif. Un montage approprié du produit est indispensable pour garantir une sécurité et une fonctionnalité maximales du véhicule. C'est pourquoi nous vous invitons à suivre scrupuleusement le manuel de montage ou à vous adresser à votre revendeur agréé.

En cas de montage ou d'utilisation non conformes de ce produit, le (quasi) constructeur ou le fournisseur déclinent toute responsabilité.
Merci !

35 ESPAÑOL

Le agradecemos que se haya decidido por este producto.

Este producto de alta calidad está probado para la competición y se ha desarrollado específicamente para las exigencias de este deporte. Para poder garantizar los máximos niveles de seguridad y funcionalidad, es imprescindible que el producto se monte correctamente. Por este motivo, es muy importante que siga las instrucciones del manual de montaje o que se ponga en contacto con su concesionario autorizado.

El (cuasi) fabricante y el proveedor de este producto no se harán responsables del montaje y el uso incorrectos.
¡Muchas gracias!



Lieferumfang

- 1x Heizgriff links ①
- 1x Heizgriff rechts ②

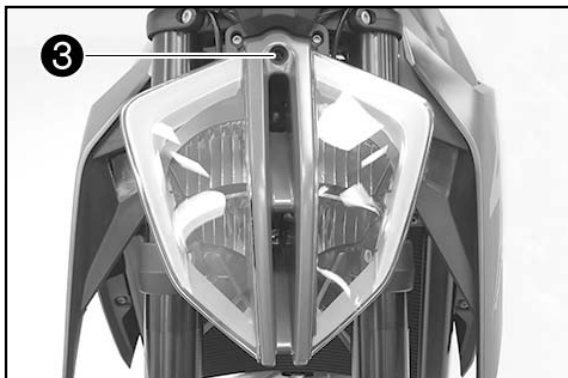

1290 Super Duke R Vorarbeit

- Alle Stromverbraucher ausschalten und Motor abstellen.

Montage

- Schraube ③ lösen.
- Scheinwerfer nach vorne schwenken.

HINWEIS

Bauteile durch Abdecken vor Beschädigungen schützen.

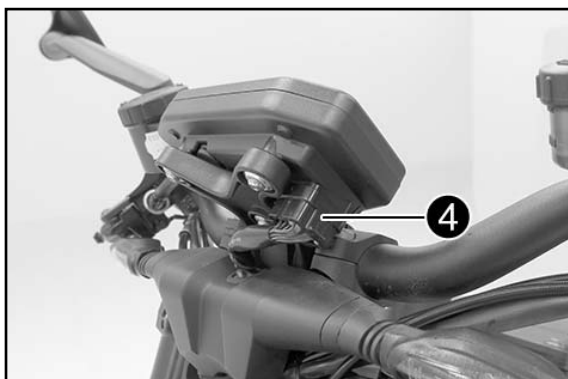

- Stecker ④ abstecken.



- Schrauben ⑤ mit Buchsen entfernen.
- Kombiinstrument abnehmen.

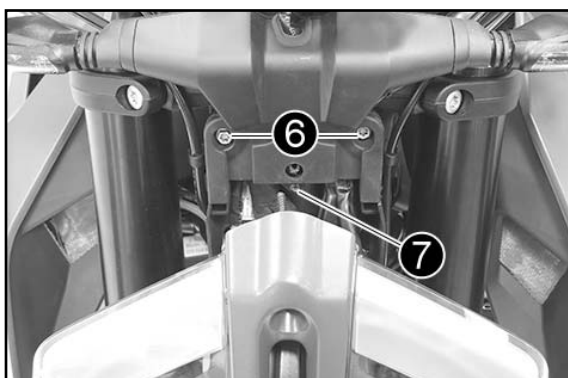

- Schrauben ⑥ entfernen.
- Schrauben ⑦ entfernen.

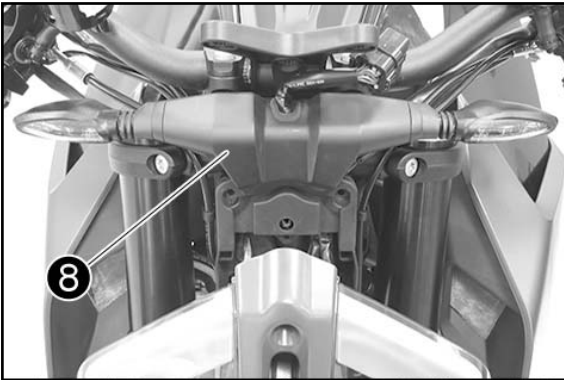

- Blinker leicht nach hinten drücken.
- Haltenasen **A** von der Blinkerhalterung lösen.
- Abdeckung **8** abnehmen.

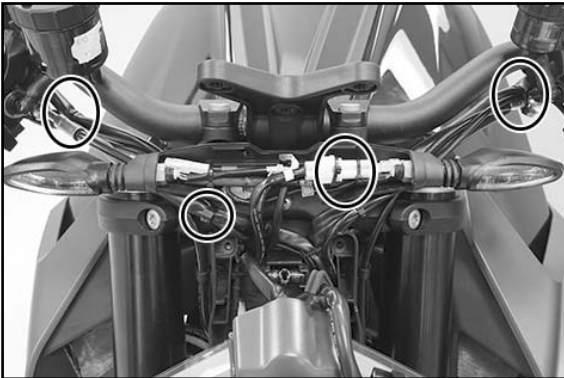
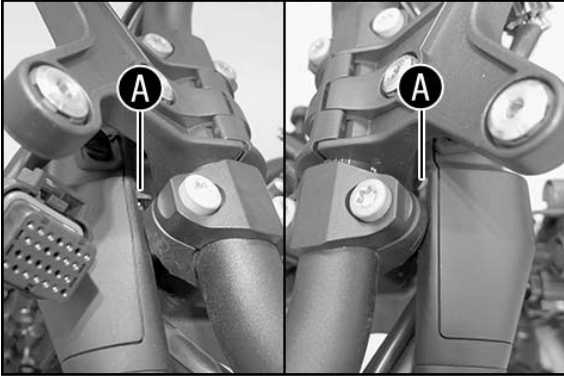

- Die 5 markierten Kabelbinder entfernen.

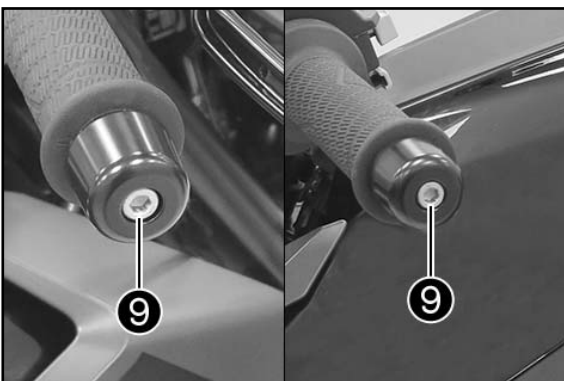

- Schraube **9** beidseitig lösen.
- Lenkergewicht beidseitig entfernen.

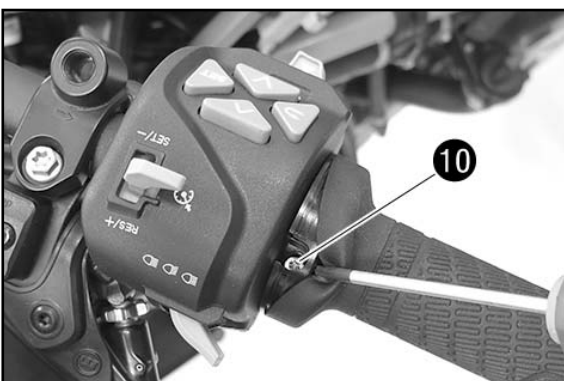

- Griffgummi links leicht anheben.
- Schraube **10** lösen.
- Festgriff links entfernen.

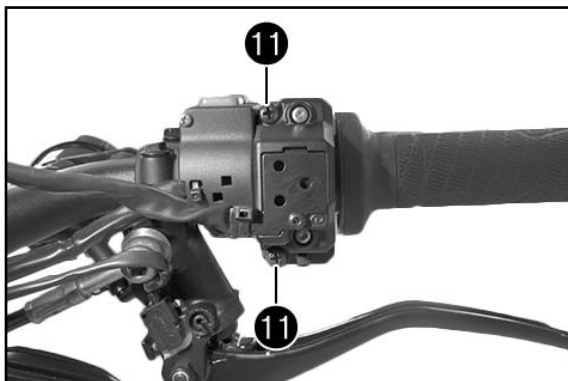

- Schrauben 11 entfernen.
- Abdeckung abnehmen.
- Gasdrehgriff und Gasdrehgriffsensor vom Lenker ziehen.

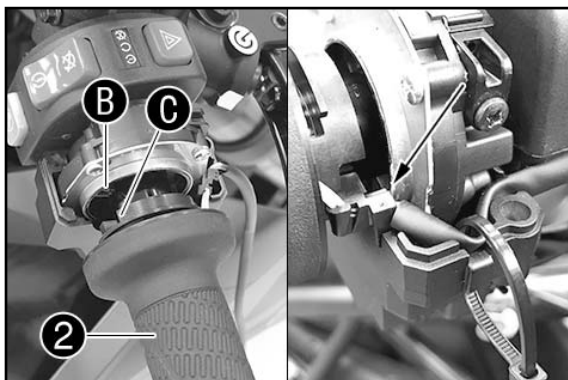

- Gasdrehgriffsensor und Heizgriff rechts 2 (Lieferumfang) am Lenker positionieren.

✓ Die Nase B greift im Mitnehmer C ein.

- Kabel im Gasdrehgriffsensor spannungsfrei verlegen (wie dargestellt) und mit Kabelbinder sichern.

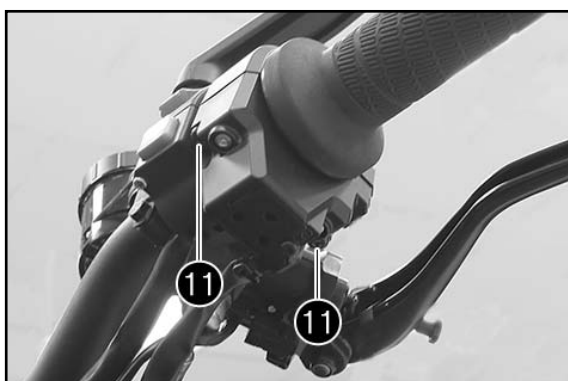

- Abdeckung positionieren.

! VORSICHT

Sicher stellen, dass das Kabel nicht geknickt oder geklemmt werden kann!

- Original-Schrauben 11 montieren und mit 3,5 Nm festziehen.

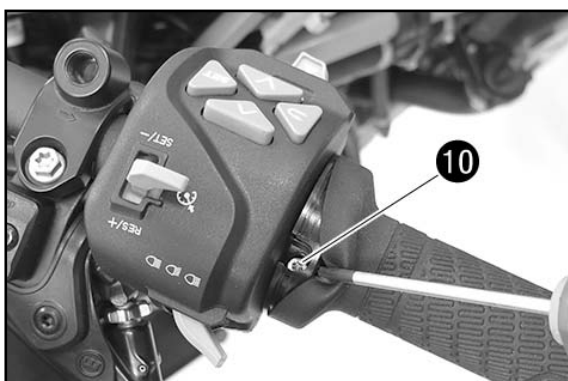

- Heizgriff links 1 (Lieferumfang) am Lenker positionieren.
- Griffgummi leicht anheben.
- Schraube 10 festziehen.

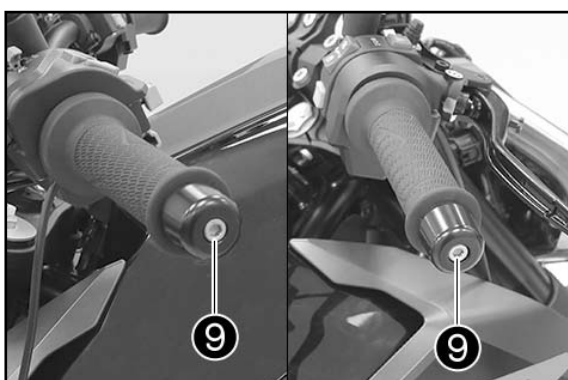

- Lenkergewicht beidseitig montieren.
- Schraube 9 beidseitig festziehen.

⚠ ACHTUNG

Gasdrehgriff auf Leichtgängigkeit kontrollieren!

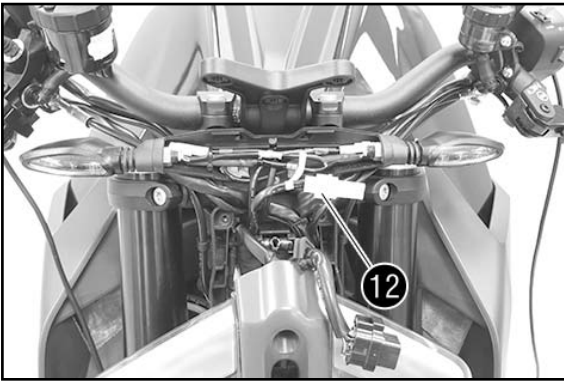

- Schutzkappe vom Stecker 12 entfernen und aufbewahren.

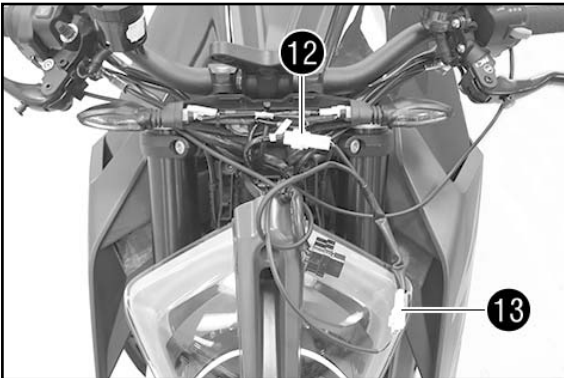

- Kabel beidseitig entlang der vorhandenen Kabel zur Scheinwerfermaske verlegen.
 - Steckerverbindung 13 der beiden Heizgriffe zusammenstecken.
 - Steckerverbindung 12 zusammenstecken.

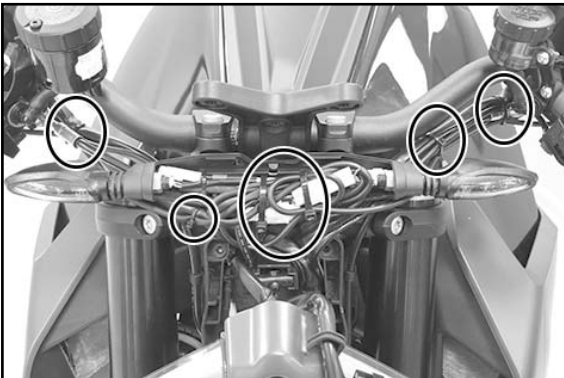

- Kabel spannungsfrei verlegen und mit Kabelbinder sichern.

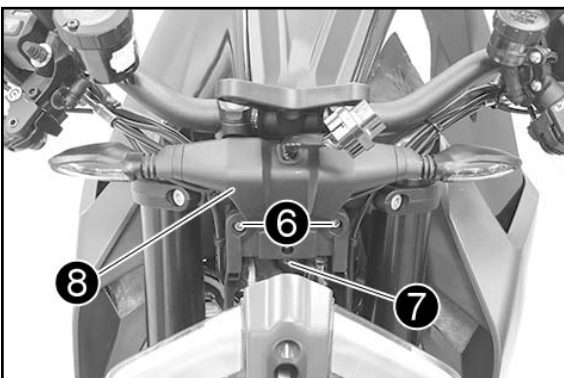

- Abdeckung 8 positionieren.

✓ Haltenasen A greifen in den Blinkerträger ein.

- Original-Schrauben 6 montieren und mit 3 Nm festziehen.

- Original-Schraube 7 montieren und mit 2 Nm festziehen.

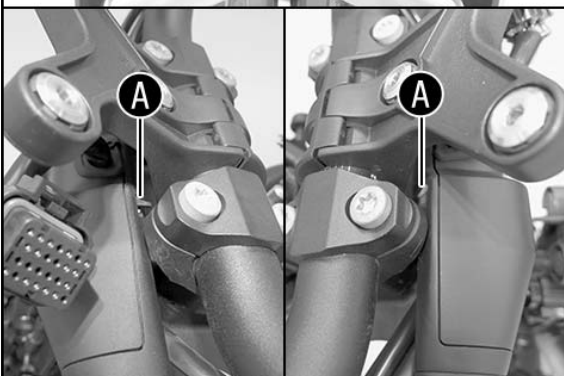

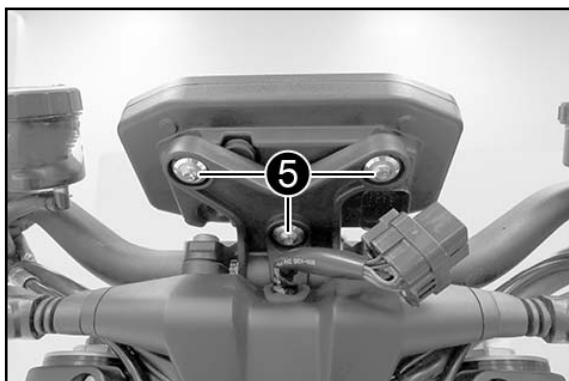

- Kombiinstrument positionieren.
- Original-Schrauben ⑤ mit Buchsen montieren und mit 2 Nm festziehen.

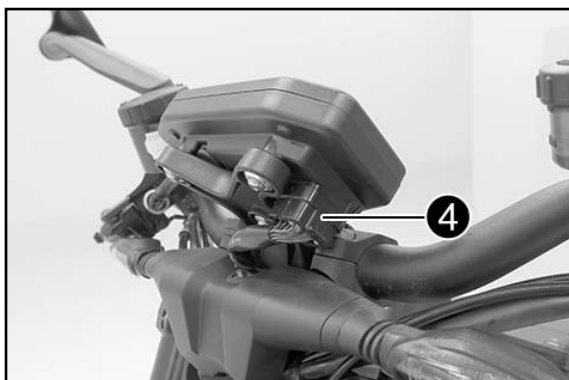

- Stecker ④ anstecken.

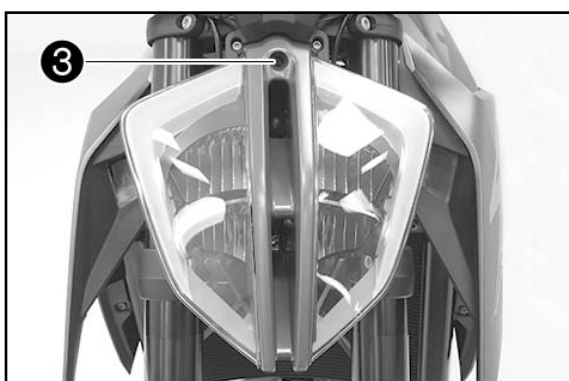

- Scheinwerfer positionieren.
- Schraube ③ montieren, aber nicht festziehen.

Nacharbeit

- Einstellung der Lichtanlage kontrollieren (s. Bedienungsanleitung).
- Scheinwerfer einstellen (s. Bedienungsanleitung).

Bedienung

- Im Menü unter „Optionen“ die Griffheizung aktivieren.
- Durch das Menü navigieren bis „Griffheizung“ im Display angezeigt wird.
- Menü öffnen und eine Heizstufe auswählen oder die Heizgriffe an- und ausschalten.

1290 Super Adventure R/S

Vorarbeit

- Alle Stromverbraucher ausschalten und Motor abstellen.
- Kraftstofftank ausbauen (s. Reparaturanleitung).

HINWEIS

Zur besseren Verlegung der Kabel werden die folgenden Arbeitsschritte bei ausgebautem Tank gezeigt. Ein Ausbau ist nicht unbedingt erforderlich.



Alle Arbeiten, die mit diesem Symbol gekennzeichnet sind, erfordern Fachkenntnisse und technisches Verständnis. Lassen Sie diese Arbeiten, im Interesse Ihrer eigenen Sicherheit, in einer autorisierten KTM- Fachwerkstatt durchführen! Dort wird Ihr Motorrad von speziell geschulten Fachkräften mit dem erforderlichen Spezialwerkzeug optimal betreut.

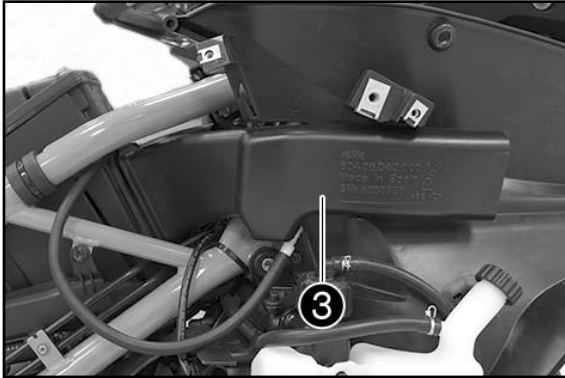

Montage

- Ansaugschnorchel ③ entfernen.

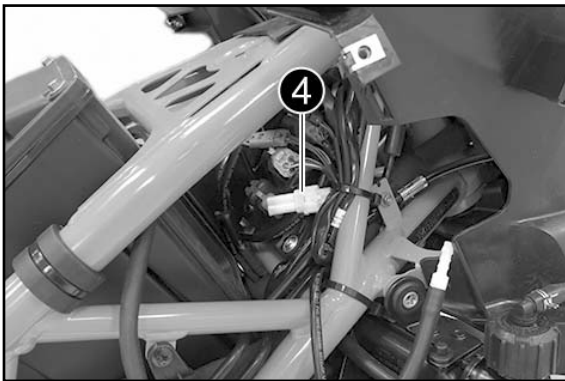

- Schutzkappe vom Stecker ④ entfernen und aufbewahren.

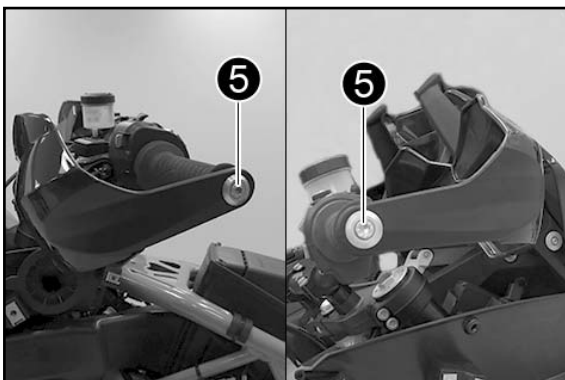

- Schraube ⑤ beidseitig lösen.
- Handschützer leicht zur Seite drücken.

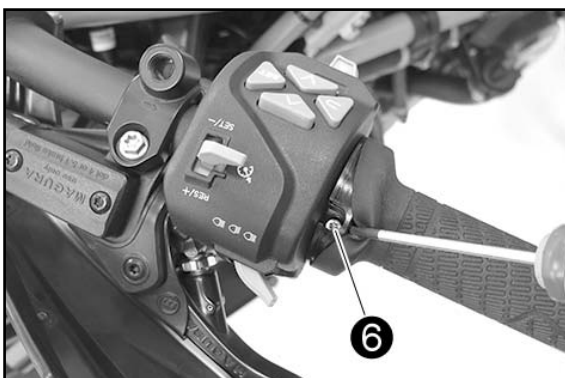

- Griffgummi links leicht anheben.
- Schraube ⑥ lösen.
- Festgriff links entfernen.



- Schrauben 7 entfernen.
- Abdeckung abnehmen.
- Gasdrehgriff und Gasdrehgriffsensor vom Lenker ziehen.

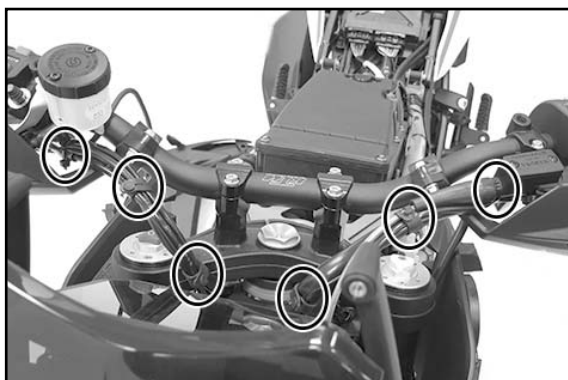

- Die 6 markierten Kabelbinder entfernen.

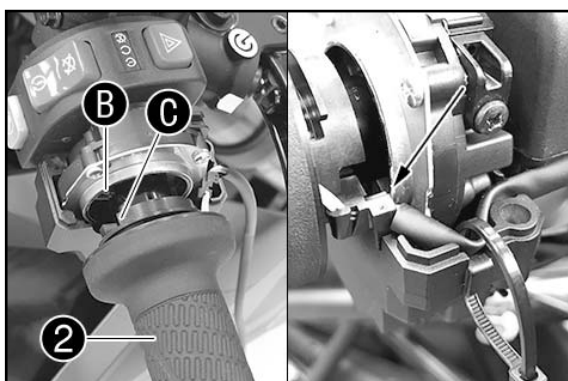

- Gasdrehgriffsensor und Heizgriff rechts 2 (Lieferumfang) am Lenker positionieren.

✓ Die Nase B greift im Mitnehmer C ein.

- Kabel im Gasdrehgriffsensor spannungsfrei verlegen (wie dargestellt) und mit Kabelbinder sichern.



- Abdeckung positionieren.

! VORSICHT

Sicher stellen, dass das Kabel nicht geknickt oder geklemmt werden kann!

- Original-Schrauben 7 montieren und mit 3,5 Nm festziehen.

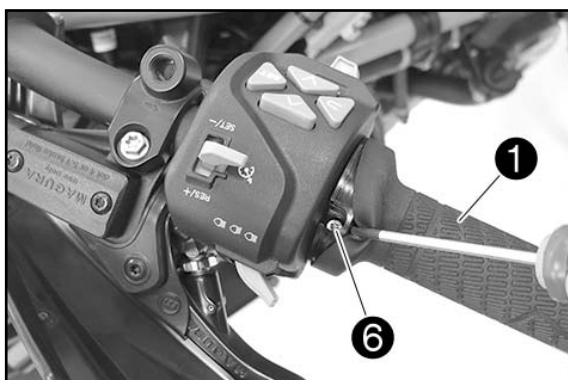

- Heizgriff links 1 (Lieferumfang) am Lenker positionieren.
- Griffgummi leicht anheben.
- Schraube 6 festziehen.

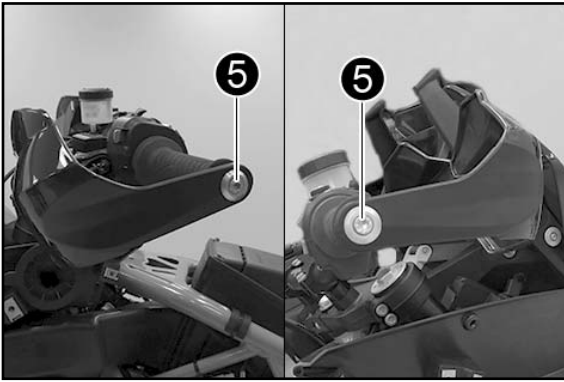

- Handschützer positionieren.
- Schraube 5 beidseitig mit 15 Nm festziehen.

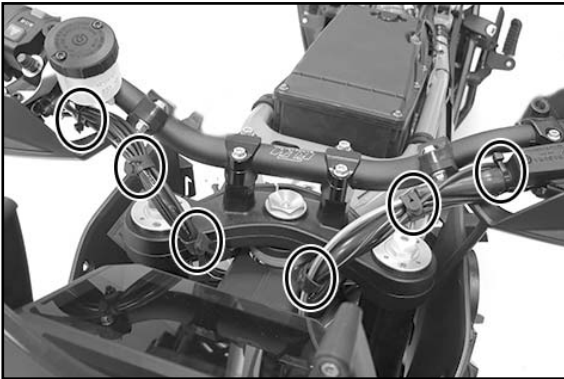

- Kabel beidseitig entlang der vorhandenen Kabel zum Stecker 4 spannungsfrei verlegen und mit Kabelbinder sichern.

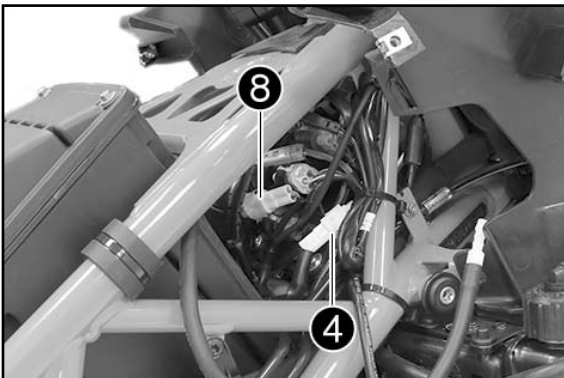

- Steckerverbindung 8 der beiden Heizgriffe zusammenstecken.
- Steckerverbindung 4 zusammenstecken.
- Kabel spannungsfrei verlegen und mit Kabelbinder sichern.

! VORSICHT
Sicher stellen, dass die Kabel nicht geknickt oder geklemmt werden können!



- Ansaugschnorchel 3 montieren.

Nacharbeit

- Kraftstofftank einbauen (s. Reparaturanleitung). 🔧

Bedienung

- Im Menü unter „Optionen“ die Griffheizung aktivieren.
- Durch das Menü navigieren bis „Griffheizung“ im Display angezeigt wird.
- Menü öffnen und eine Heizstufe auswählen oder die Heizgriffe an- und ausschalten.



Scope of supply

- 1x heated grip, left ①
- 1x heated grip, right ②

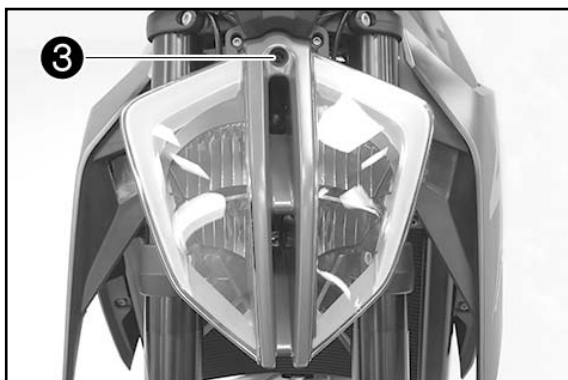

1290 Super Duke R Preparatory work

- Switch off all power consumers and switch off the engine.

Assembly

- Release screw ③.
- Swing the headlight toward the front.

NOTE

Cover the components to protect them against damage.

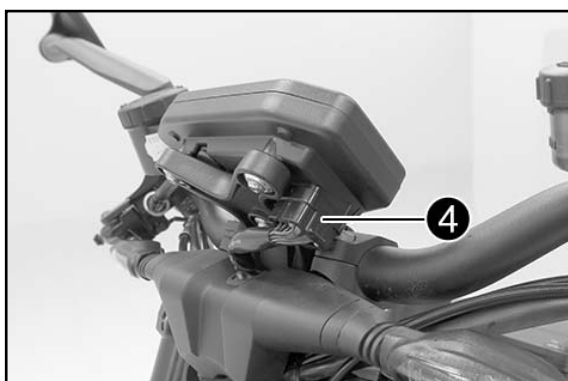

- Unplug connector ④.



- Remove screws ⑤ with bushings.
- Remove the combination instrument.

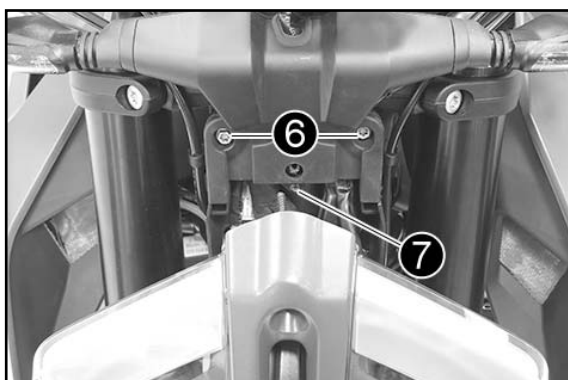

- Remove screws ⑥.
- Remove screws ⑦.

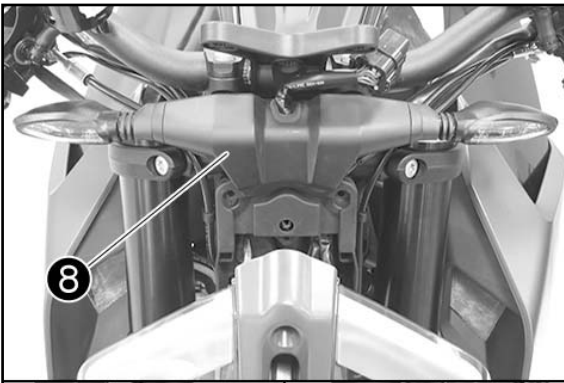

- Press the turn signal back slightly.
- Remove holding lugs **A** from the turn signal bracket.
- Take off cover **8**.

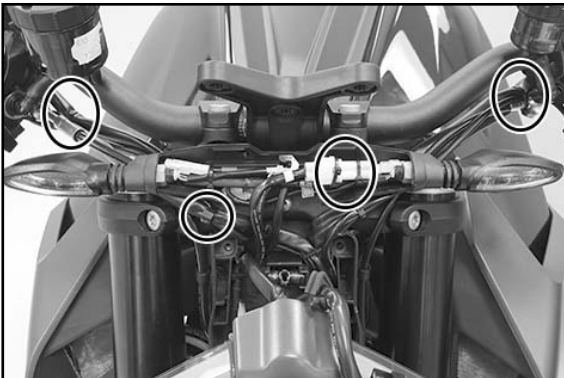
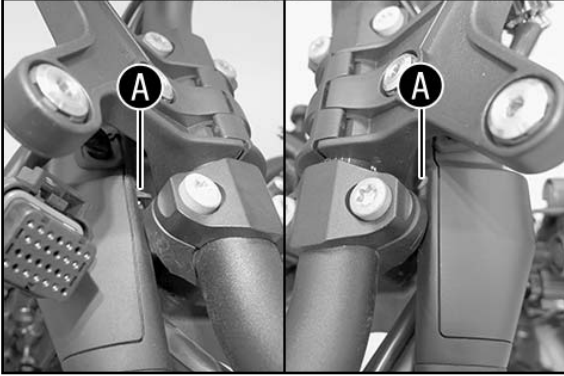

- Remove the 5 marked cable ties.

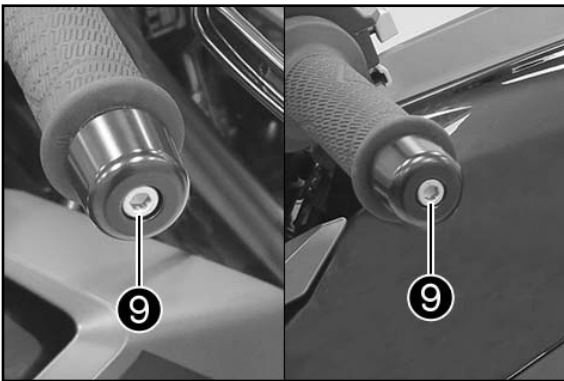

- Release screw **9** on both sides.
- Remove the handlebar weights from both sides.

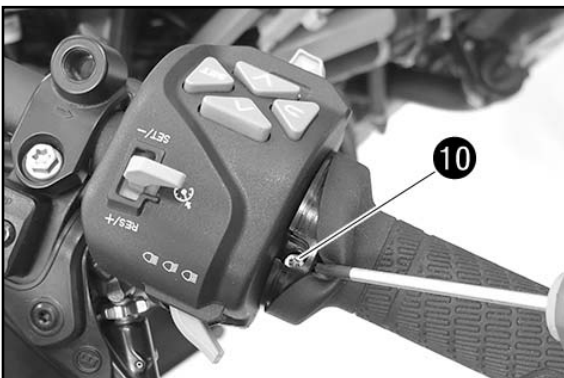

- Slightly raise the left rubber grip.
- Remove screw **10**.
- Remove the left fixed grip.

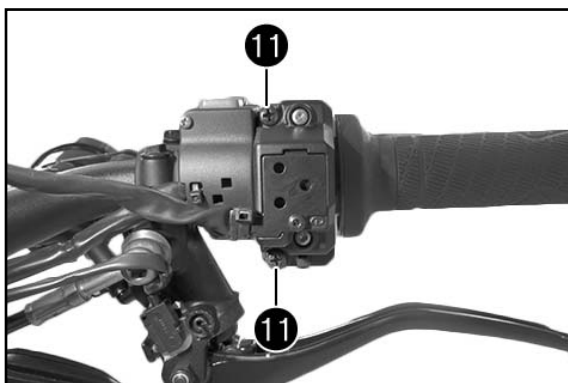

- Remove screws 11.
- Take off the cover.
- Pull the throttle grip and accelerator position sensor from the handlebar.

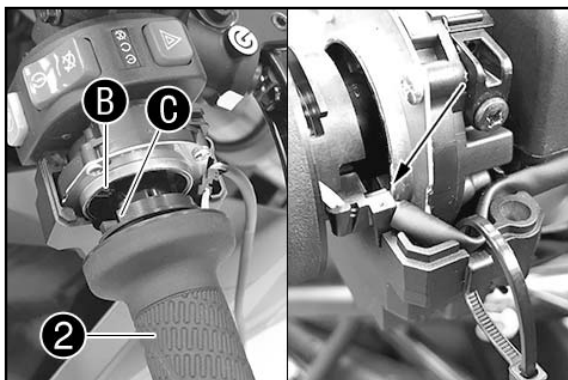

- Position the accelerator position sensor and right heated grip 2 (scope of supply) on the handlebar.

✓ Catch B engages in driver C.

- Route the cable in the accelerator position sensor so it is not under tension (as shown) and secure with a cable tie.

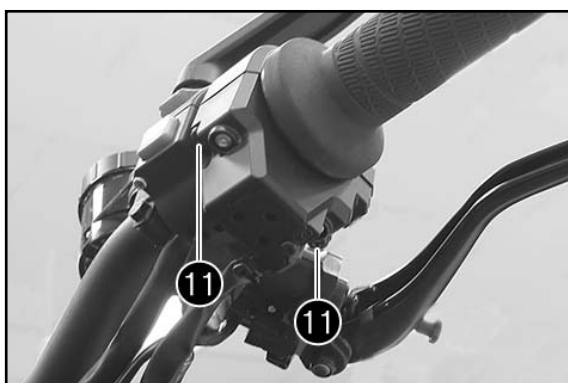

- Position the cover.

! ATTENTION

Ensure that the cable can neither be kinked or pinched!

- Mount original screws 11 and tighten to 3.5 Nm.

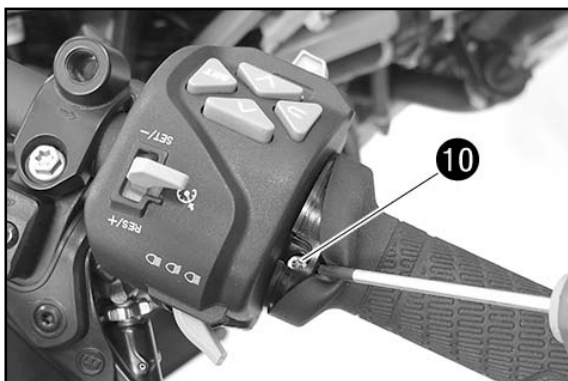

- Position left heated grip 1 (scope of supply) on the handlebar.
- Slightly raise the rubber grip.
- Tighten screw 10.

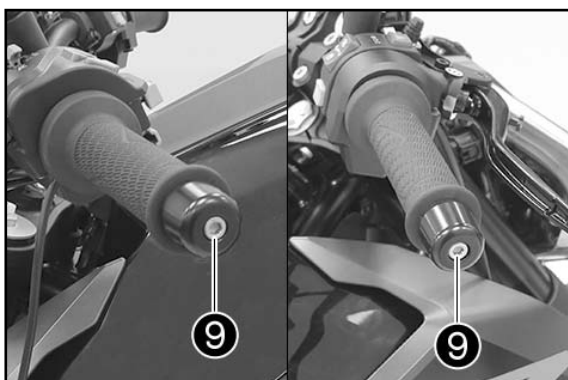

- Mount the handlebar weights on both sides.
- Tighten screw 9 on both sides.

⚠ WARNING

Check the throttle grip for smooth operation!

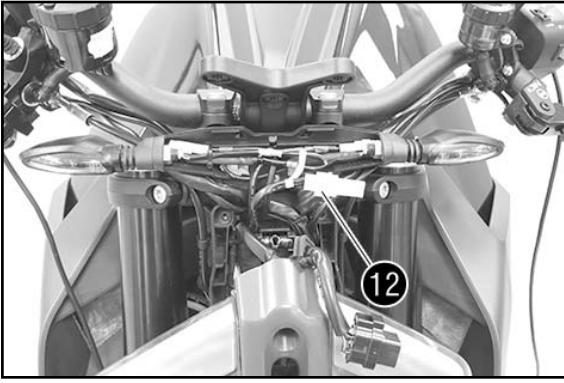

- Remove the protection cap from diagnostics connector 12 and keep in a safe place.

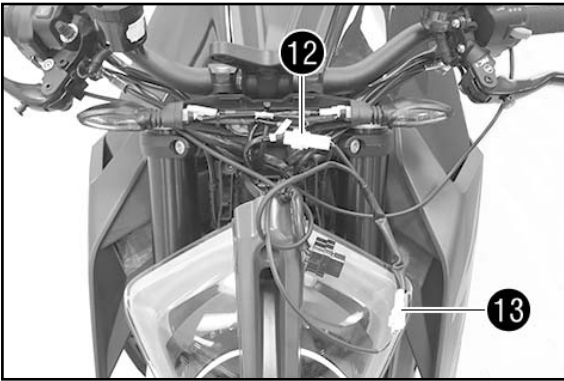

- Route the cable on both sides along the existing cables to the headlight mask.
- Join plug-in connector 13 of the two heated grips.
- Join plug-in connector 12.

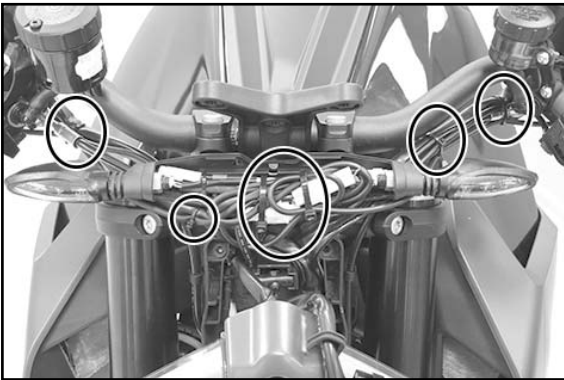

Route the cable without tension and secure with cable tie.

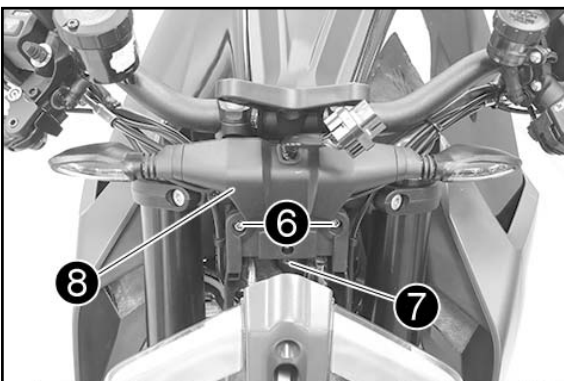

- Position cover 8.
- ✓ Holding lugs A engage in the turn signal carriers.
- Mount original screws 6 and tighten to 3 Nm.
- Mount original screw 7 and tighten to 2 Nm.

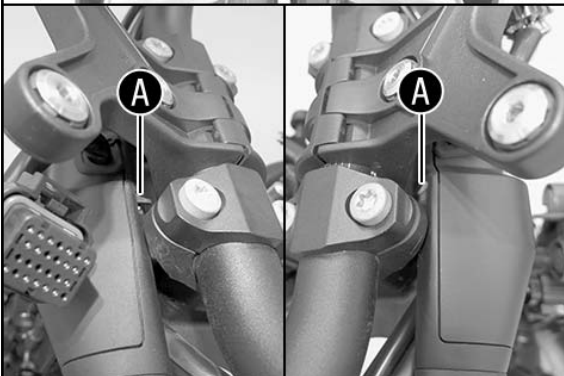

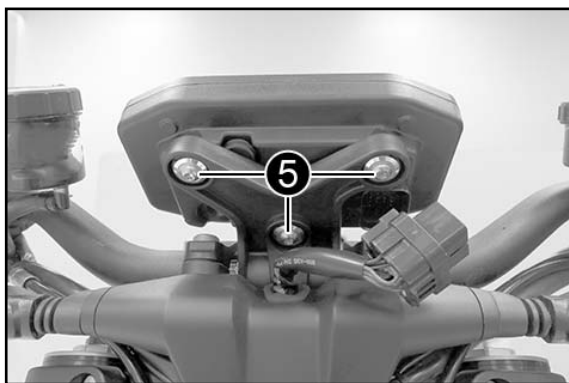

- Position the combination instrument.
- Mount original screws **5** with bushings and tighten to 2 Nm.

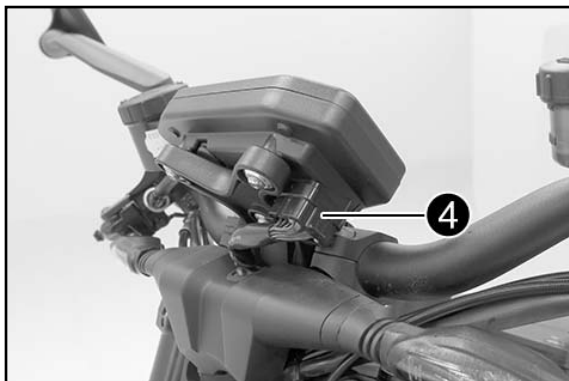

- Plug in connector **4**.

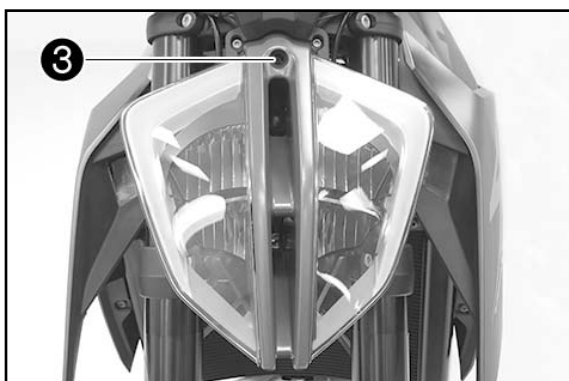

- Position the headlight.
- Mount screw **3** but do not tighten yet.

Final steps

- Check the setting of the lighting system (see the Owner's Manual).
- Adjust the headlamp (see the Owner's Manual).

Operation

- Activate the grip heater in the menu under "Settings".
- Navigate through the menu until "grip heater" is shown in the display.
- Open the menu and select a heating level or switch the heated grips on or off.

1290 Super Adventure R/S

Preparatory work

- Switch off all power consumers and switch off the engine.
- Remove the fuel tank (see the Repair Manual). 

NOTE

For better routing of the cables, the following steps are shown with the tank removed. Removal is not absolutely necessary.



All work marked with this symbol requires specialist knowledge and technical understanding.

For your own safety, please have this work performed in an authorized KTM workshop!

There, your motorcycle will be optimally cared for by specially trained experts using the specialist tools required.

» ENGLISH

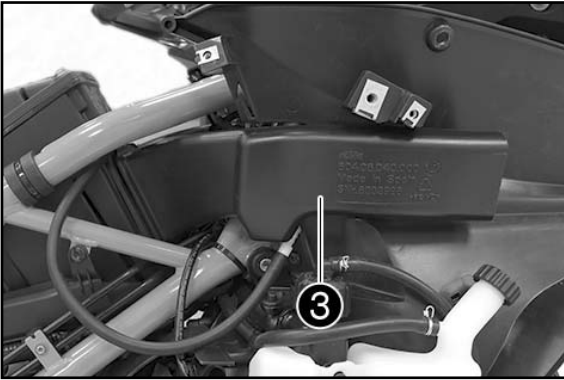

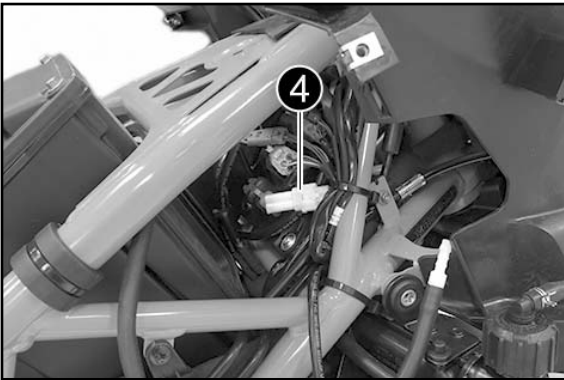

Assembly

- Remove intake snorkel .

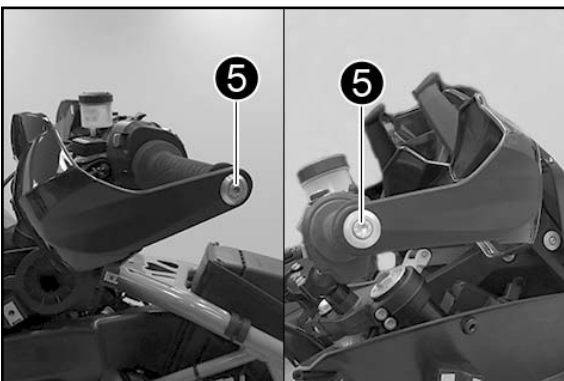

- Remove the protection cap from connector  and keep in a safe place.



- Release screw  on both sides.
- Push the hand guard slightly to the side.

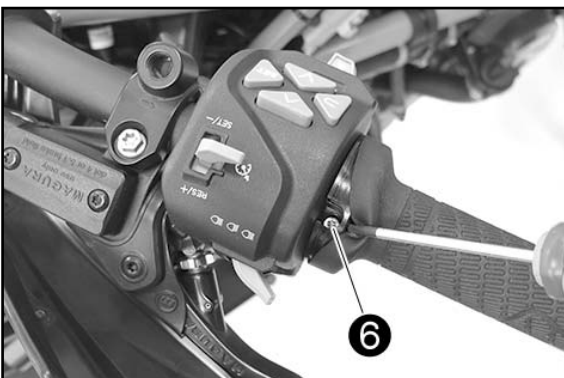

- Slightly raise the left rubber grip.
- Release screw .
- Remove the left fixed grip.



- Remove screws 7.
- Take off the cover.
- Pull the throttle grip and accelerator position sensor from the handlebar.

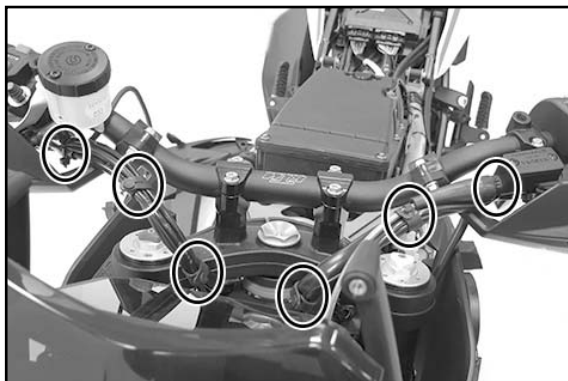

- Remove the 6 marked cable ties.

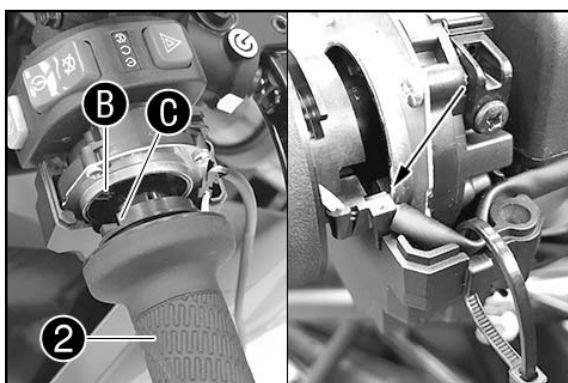

- Position the accelerator position sensor and right heated grip 2 (scope of supply) on the handlebar.

✓ Catch B engages in driver C.

- Route the cable in the accelerator position sensor so it is not under tension (as shown) and secure with a cable tie.



- Position the cover.

! ATTENTION
Ensure that the cable can neither be kinked or pinched!

- Mount original screws 7 and tighten to 3.5 Nm.

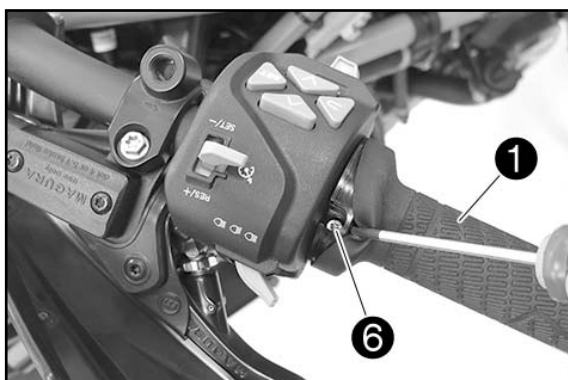

- Position left heated grip 1 (scope of supply) on the handlebar.
- Slightly raise the rubber grip.
- Tighten screw 6.

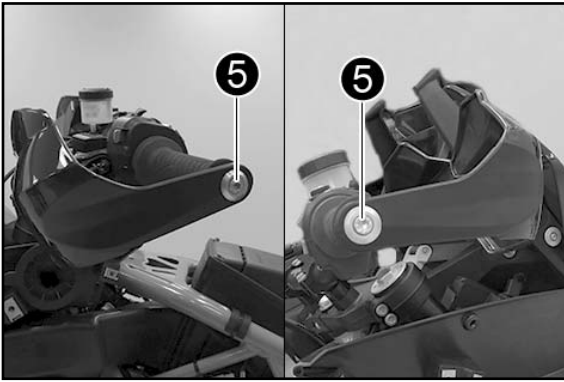

- Position the hand guard.
- Tighten screw 5 to 15 Nm on both sides.

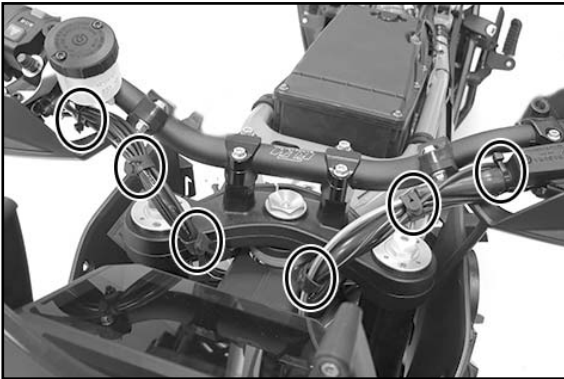

- Route the cable on both sides along the existing cables to connector 4 so it is not under tension and secure with a cable tie.

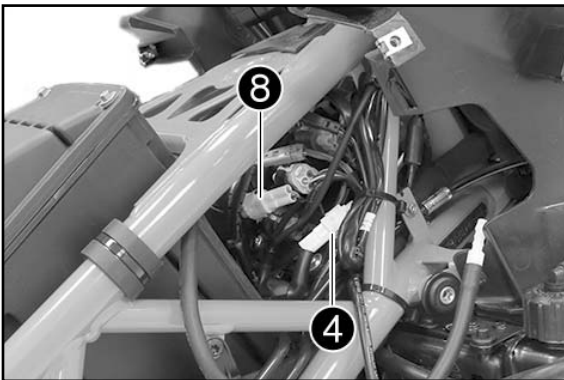

- Join plug-in connector 8 of the two heated grips.
- Connect plug-in connection 4.
- Route the cable without tension and secure with cable tie.

! ATTENTION
Ensure that the cables can neither become kinked or pinched!



- Mount intake snorkel 3.

Final steps

- Install the fuel tank (see the repair manual). 🔧

Operation

- Activate the grip heater in the menu under "Settings".
- Navigate through the menu until "grip heater" is shown in the display.
- Open the menu and select a heating level or switch the heated grips on or off.



Materiale fornito

- 1 manopola riscaldabile sinistra ❶
- 1 manopola riscaldabile destra ❷

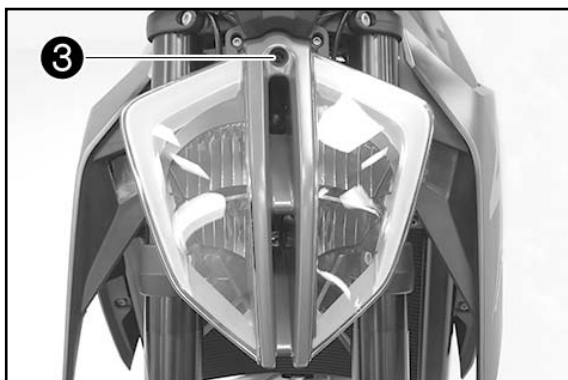

1290 Super Duke R Operazione preliminare

- Disattivare tutte le utenze elettriche e spegnere il motore.

Montaggio

- Allentare la vite ❸.
- Ruotare il faro in avanti.

AVVERTENZA

Coprire i componenti per evitare di danneggiarli.

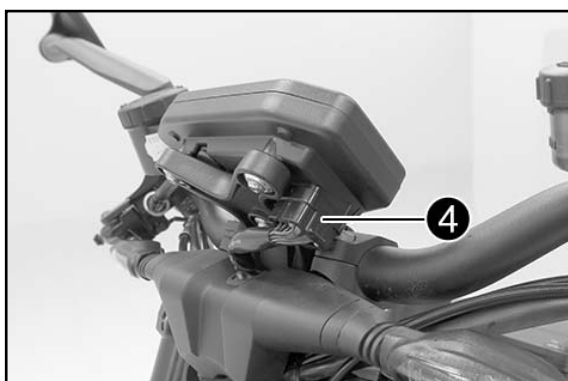

- Staccare il connettore ❹.



- Rimuovere le viti ❺ con le boccole.
- Rimuovere il quadro strumenti.

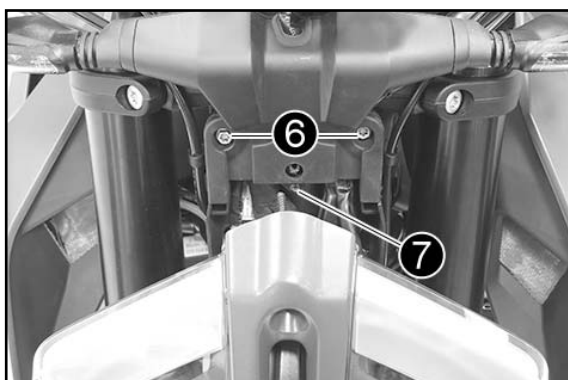

- Rimuovere le viti ❻.
- Rimuovere le viti ❼.



- Spingere delicatamente indietro l'indicatore di direzione.
- Allentare i naselli d'ancoraggio **A** del sostegno dell'indicatore.
- Rimuovere il coperchio **8**.

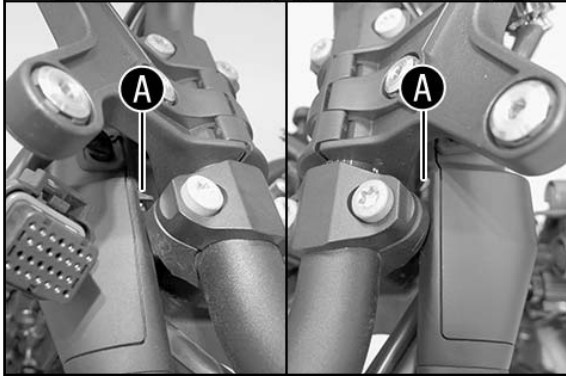

- Rimuovere le 5 fascette contrassegnate.

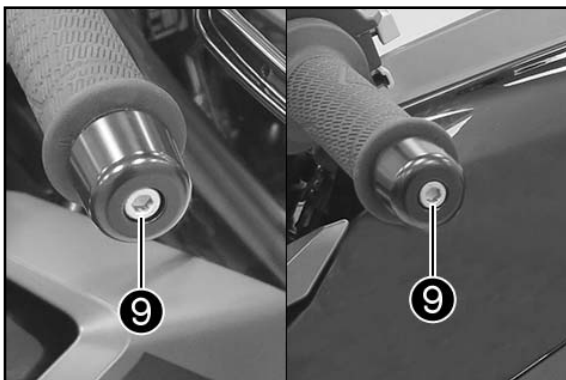

- Svitare la vite **9** su entrambi i lati.
- Rimuovere il contrappeso del manubrio su entrambi i lati.

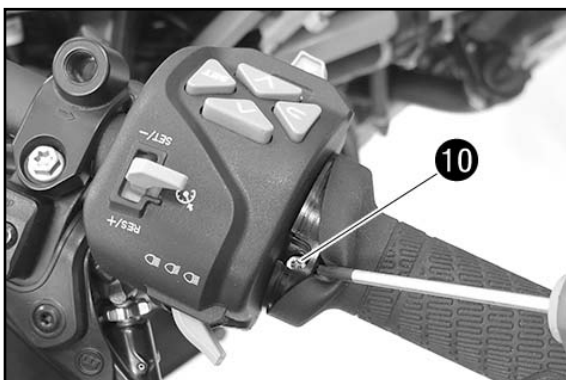

- Sollevare leggermente la manopola sinistra.
- Svitare la vite **10**.
- Rimuovere la manopola fissa sinistra.

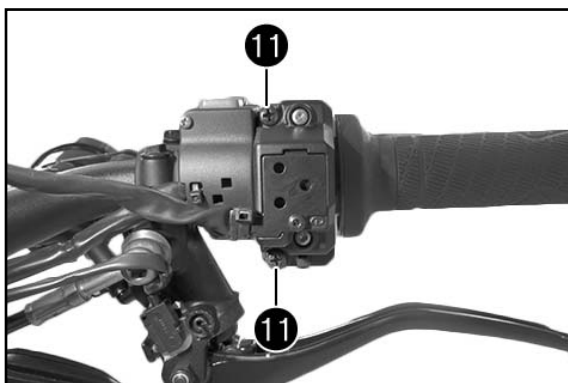

- Rimuovere le viti 11.
- Rimuovere il coperchio.
- Staccare dal manubrio la manopola dell'acceleratore e il sensore manopola dell'acceleratore.

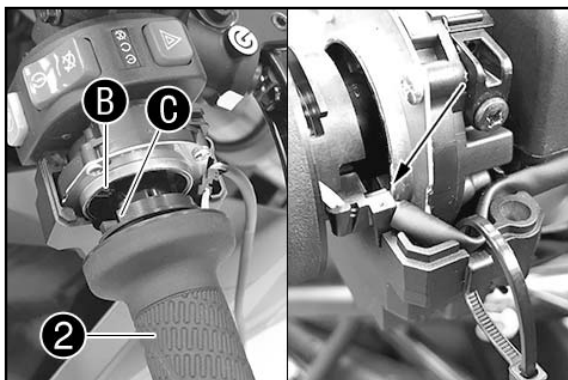

- Posizionare il sensore manopola dell'acceleratore e la manopola riscaldabile destra 2 (in dotazione) sul manubrio.

✓ Il nasello B si innesta nel mozzo C.

- Posizionare il cavo sul sensore manopola dell'acceleratore in modo da non metterlo in tensione (come mostrato) e assicurarne con una fascetta.

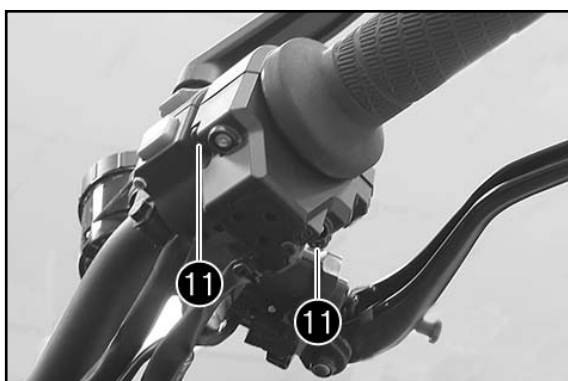

- Posizionare il coperchio.

! ATTENTION

Assicurarsi che il cavo non rischi di venire piegato o bloccato in qualche modo!

- Montare le viti originali 11 e serrarle a 3,5 Nm.

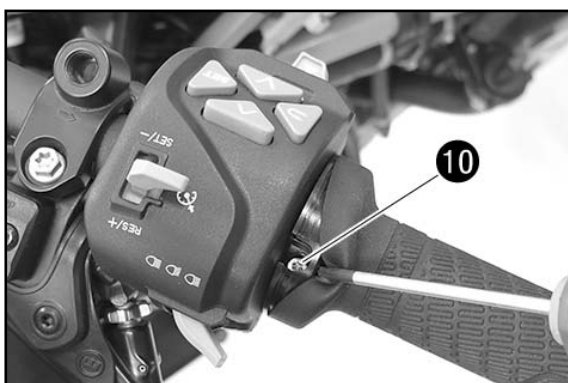

- Posizionare la manopola riscaldabile sinistra 1 (in dotazione) sul manubrio.
- Sollevare leggermente la manopola.
- Serrare la vite 10.

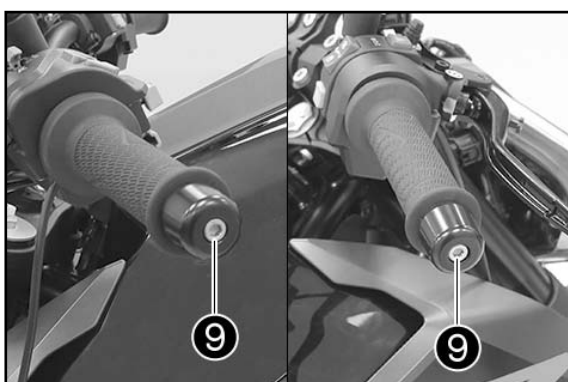

- Montare il contrappeso del manubrio su entrambi i lati.
- Serrare la vite 9 su entrambi i lati.

⚠ WARNING

Controllare la scorrevolezza della manopola dell'acceleratore!

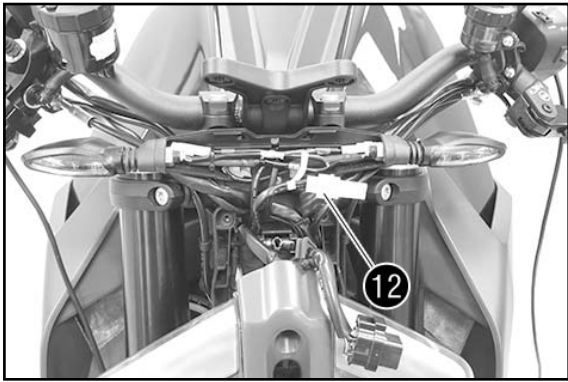

- Rimuovere il cappuccio protettivo dal connettore 12 e conservarlo.

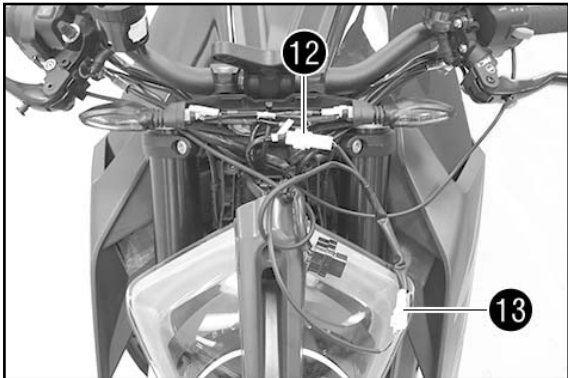

- Su entrambi i lati disporre i cavi lungo i cavi presenti portandoli verso la mascherina portafaro.
 - Collegare il connettore 13 delle due manopole riscaldabili.
 - Collegare il connettore 12.

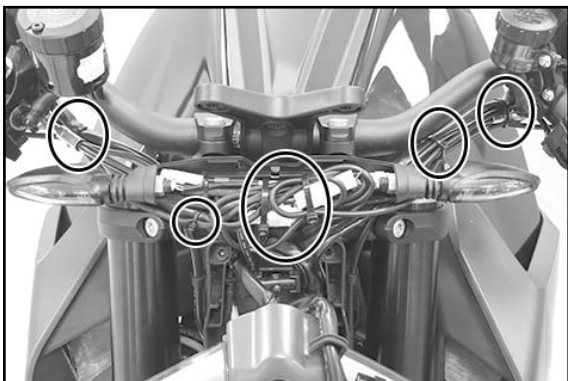

- Posizionare i cavi in modo che non presentino punti in tensione e assicurarli con delle fascette.

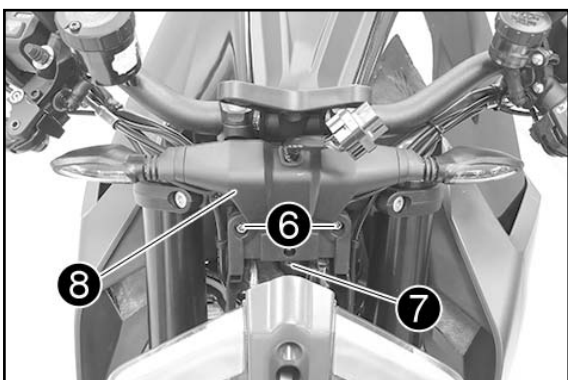

- Posizionare il coperchio 8.

✓ I naselli d'ancoraggio A si innestano nel supporto degli indicatori di direzione.

- Montare le viti originali 6 e serrarle a 3 Nm.
 - Montare la vite originale 7 e serrarla a 2 Nm.

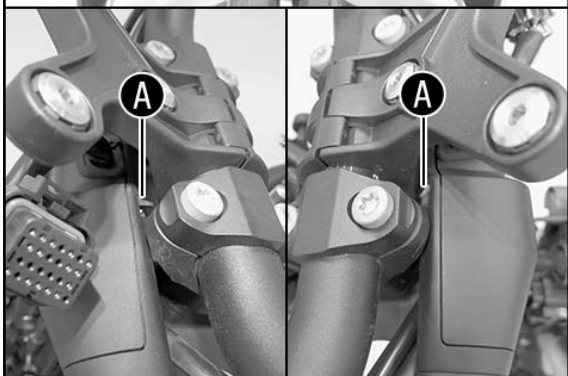

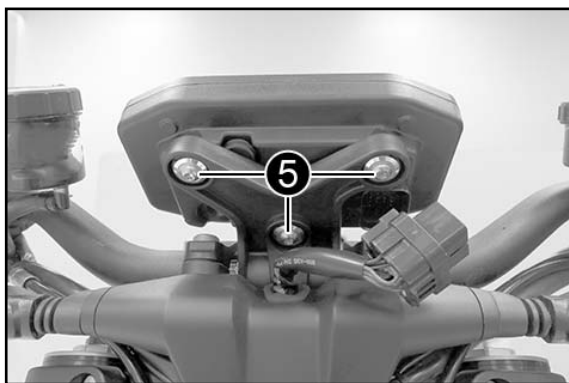

- Posizionare il quadro strumenti.
- Montare le viti originali 5 con le boccole e serrare a 2 Nm.

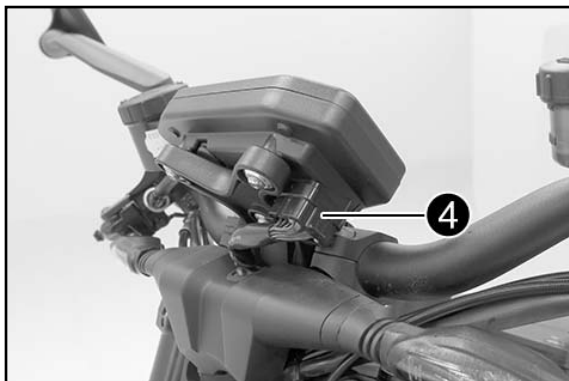

- Collegare il connettore 4.

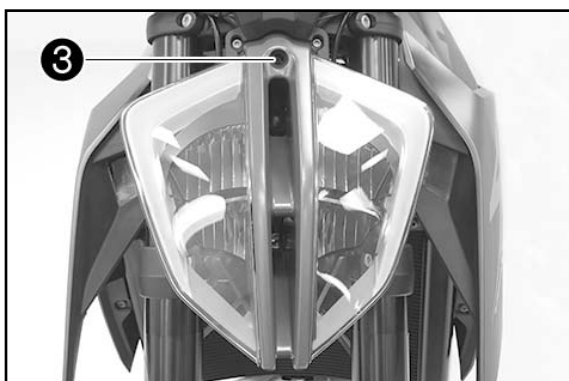

- Posizionare il faro.
- Montare la vite 3 senza stringerla.

Operazione conclusiva

- Controllare la regolazione dell'impianto luci (v. manuale d'uso).
- Regolare il faro (v. manuale d'uso).

Utilizzo

- All'interno del menu, sotto "Impostazioni", attivare il riscaldamento delle manopole.
- Attraverso il menu navigare fino a visualizzare sul display la voce "Riscaldamento delle manopole".
- Aprire il menu e selezionare un livello di riscaldamento oppure attivare/disattivare le manopole riscaldabili.

1290 Super Adventure R/S

Operazione preliminare

- Disattivare tutte le utenze elettriche e spegnere il motore.
- Smontare il serbatoio (v. manuale di riparazione). 

AVVISO

Per una migliore disposizione dei cavi le seguenti operazioni vengono mostrate con serbatoio smontato. Non è però assolutamente necessario effettuarne lo smontaggio.



Tutti i lavori contrassegnati con questo simbolo richiedono competenze tecniche e comprensione della materia. Per la vostra sicurezza, far eseguire questi interventi presso un'officina autorizzata KTM, che si occuperà della vostra moto in modo ottimale, impiegando manodopera specializzata e addestrata e con i necessari attrezzi speciali.

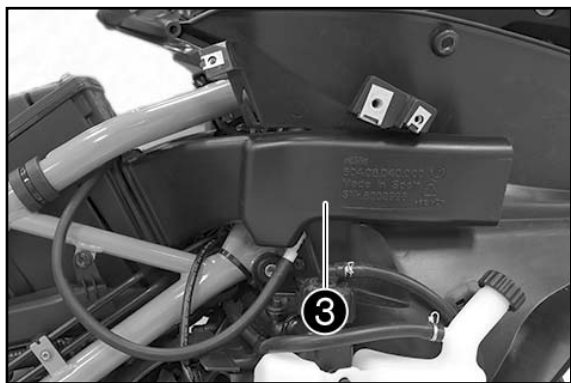

Montaggio

- Rimuovere il tubo di aspirazione ③.

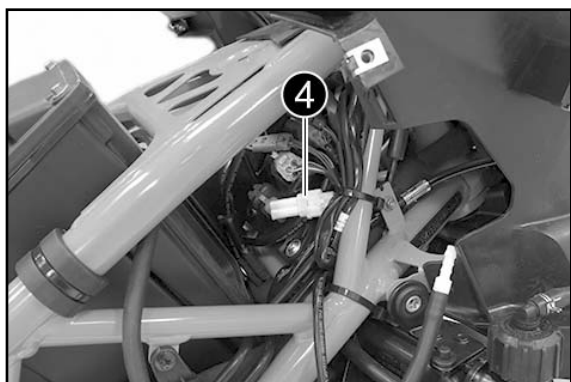

- Rimuovere il cappuccio protettivo dal connettore ④ e conservarlo.

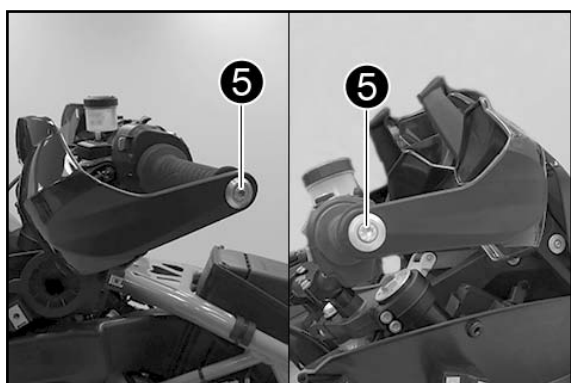

- Svitare la vite ⑤ su entrambi i lati.
- Spingere leggermente di lato i paramani.

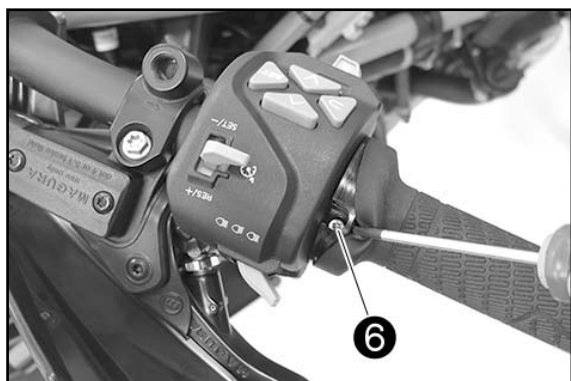

- Sollevare leggermente la manopola sinistra.
- Allentare la vite ⑥.
- Rimuovere la manopola fissa sinistra.



- Rimuovere le viti 7.
- Rimuovere il coperchio.
- Staccare dal manubrio la manopola dell'acceleratore e il sensore manopola dell'acceleratore.

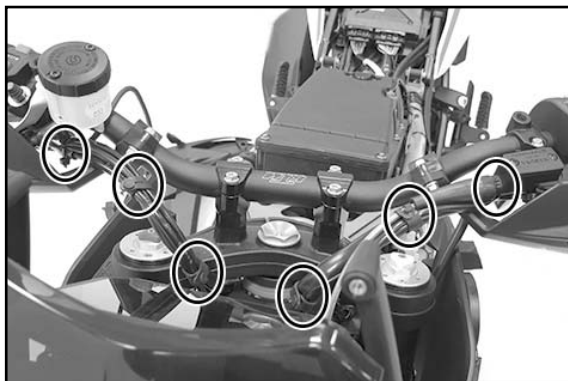

- Rimuovere le 6 fascette contrassegnate.

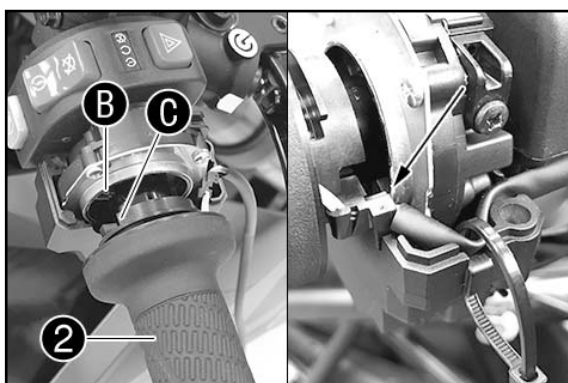

- Posizionare il sensore manopola dell'acceleratore e la manopola riscaldabile destra 2 (in dotazione) sul manubrio.

✓ Il nasello B si innesta nel mozzo C.

- Posizionare il cavo sul sensore manopola dell'acceleratore in modo da non metterlo in tensione (come mostrato) e assicurarlo con una fascetta.



- Posizionare il coperchio.

! ATTENTION

Assicurarsi che il cavo non rischi di venire piegato o bloccato in qualche modo!

- Montare le viti originali 7 e serrarle a 3,5 Nm.

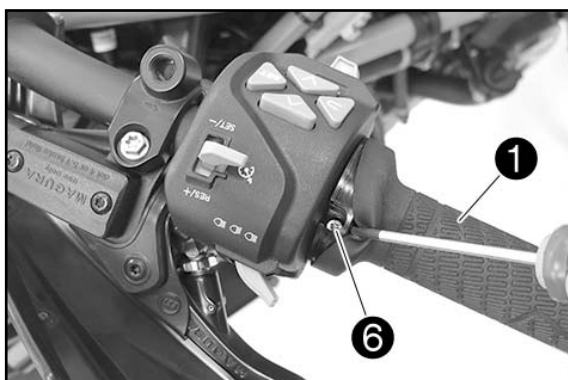

- Posizionare la manopola riscaldabile sinistra 1 (in dotazione) sul manubrio.
- Sollevare leggermente la manopola.
- Serrare la vite 6.

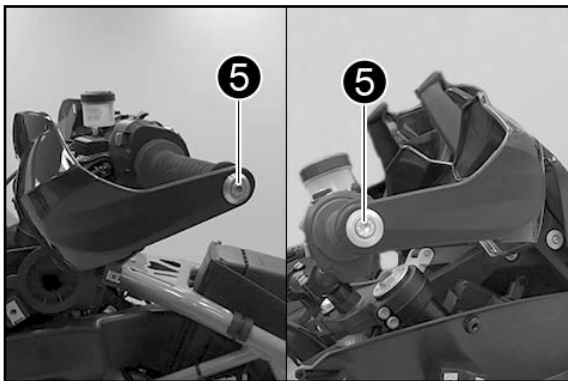

- Posizionare i paramani.
- Serrare la vite 5 su entrambi i lati a 15 Nm.

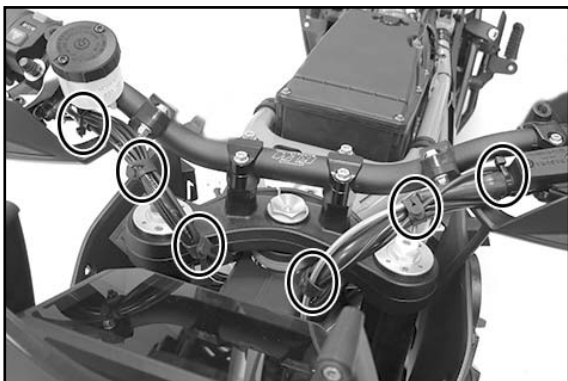

- Disporre i cavi su entrambi i lati lungo i cavi presenti in modo che non presentino punti in tensione e fino ad arrivare al connettore 4, quindi assicurare con le fascette.

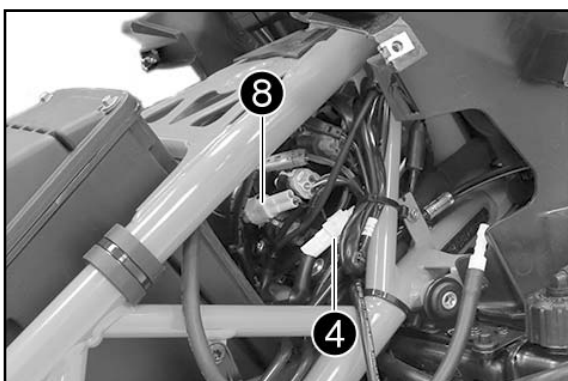

- Collegare il connettore 8 delle due manopole riscaldabili.
- Collegare il connettore 4.
- Posizionare i cavi in modo che non presentino punti in tensione e assicurarli con delle fascette.

! ATTENTION

Assicurarsi che i cavi non rischiano di venire piegati o bloccati in qualche modo!



- Montare il tubo di aspirazione 3.

Operazione conclusiva

- Montare il serbatoio (v. manuale di riparazione). 🔧

Utilizzo

- All'interno del menu, sotto "Impostazioni", attivare il riscaldamento delle manopole.
- Attraverso il menu navigare fino a visualizzare sul display la voce "Riscaldamento delle manopole".
- Aprire il menu e selezionare un livello di riscaldamento oppure attivare e disattivare le manopole riscaldabili.



Contenu de la livraison

- 1x poignée chauffante gauche ①
- 1x poignée chauffante droite ②

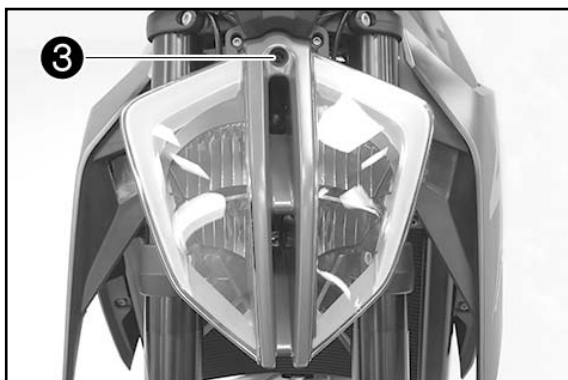

1290 Super Duke R Travaux préalables

- Désactiver tous les consommateurs de courant et arrêter le moteur.

Montage

- Desserrer la vis ③.
- Faire pivoter le phare vers l'avant.

REMARQUE

Protéger les composants de tout dommage en les recouvrant.

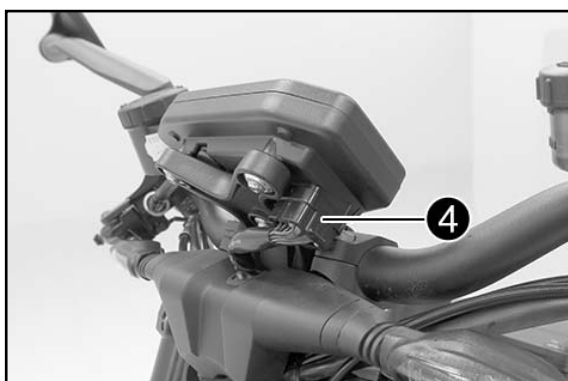

- Débrancher le connecteur ④.



- Enlever les vis ⑤ et les bagues.
- Déposer le tableau de bord.

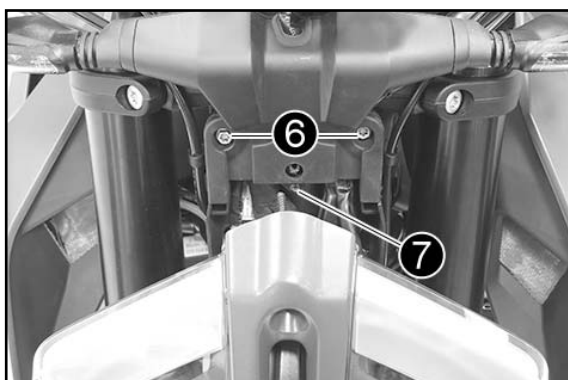

- Retirer les vis ⑥.
- Retirer les vis ⑦.

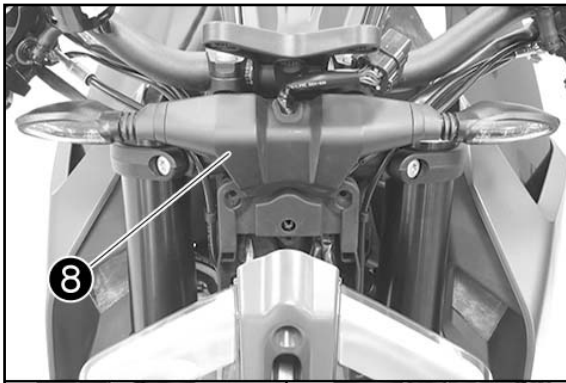

- Pousser légèrement le clignotant vers l'arrière.
- Détacher les crochets **A** du support clignotant.
- Enlever le cache **8**.

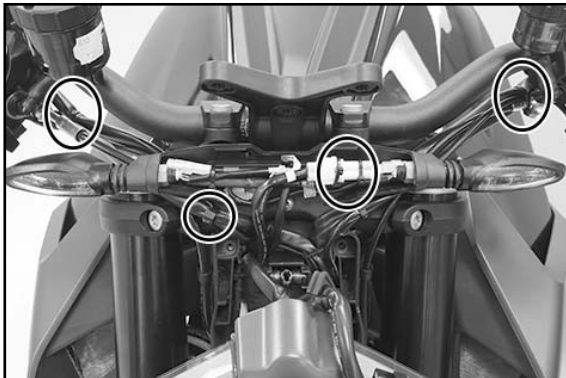
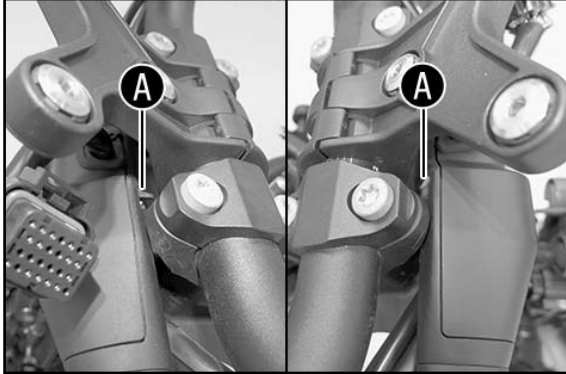

- Retirer les 5 serre-câbles indiqués.

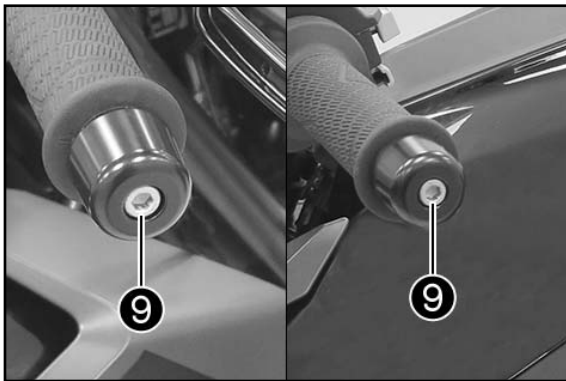

- Desserrer la vis **9** sur les côtés droit et gauche.
- Retirer le lest de guidon sur les côtés droit et gauche.

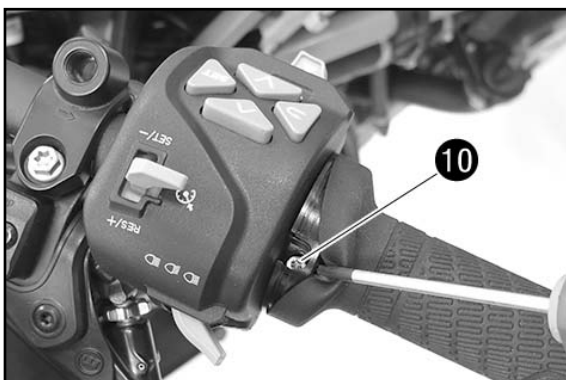

- Soulever légèrement le caoutchouc de poignée à gauche.
- Desserrer la vis **10**.
- Retirer la poignée fixe à gauche.

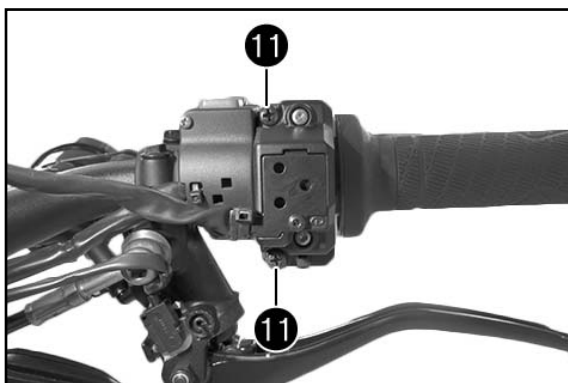

- Retirer les vis 11.
- Déposer le cache.
- Dégager la poignée des gaz et le capteur de poignée d'accélération du guidon.

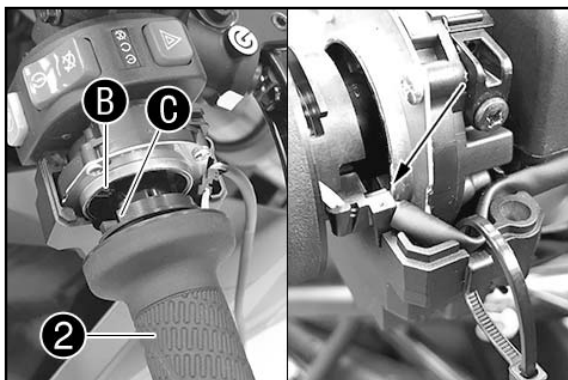

- Positionner le capteur de poignée d'accélération et la poignée chauffante droite 2 (fournie) sur le guidon.

✓ L'ergot B s'engage dans la noix d'embrayage C.

- Poser le câble du capteur de poignée d'accélération de manière à ce qu'il ne soit soumis à aucune contrainte (voir illustration) et le fixer à l'aide d'un rilsan.

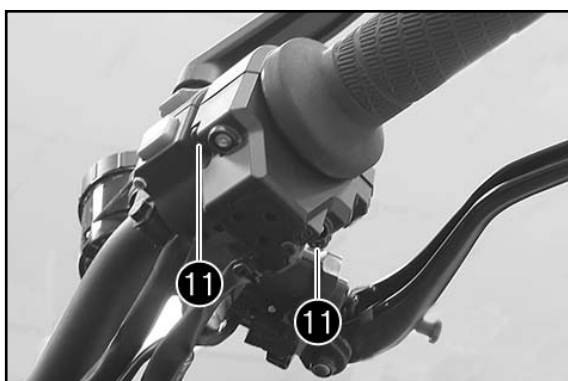

- Positionner le cache.

! ATTENTION

Veiller à ce que le câble ne soit ni plié ni coincé !

- Mettre en place les vis d'origine 11 et les serrer à 3,5 Nm.

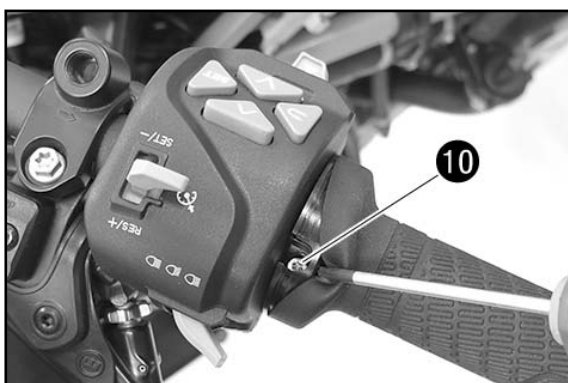

- Positionner la poignée chauffante gauche 1 (fournie) sur le guidon.
- Soulever légèrement le caoutchouc de poignée.
- Serrer la vis 10.

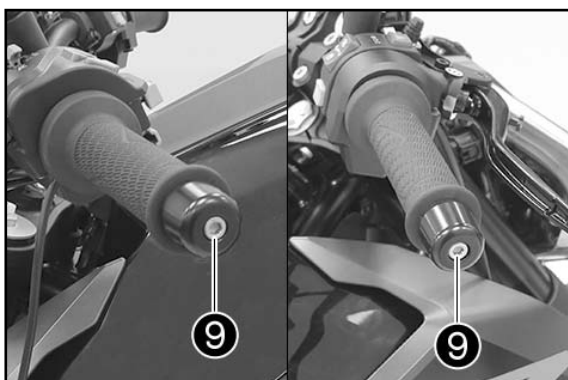

- Mettre en place le lest de guidon sur les côtés droit et gauche.
- Serrer la vis 9 sur les côtés droit et gauche.

⚠ ATTENTION

Vérifier que la poignée des gaz tourne sans effort !

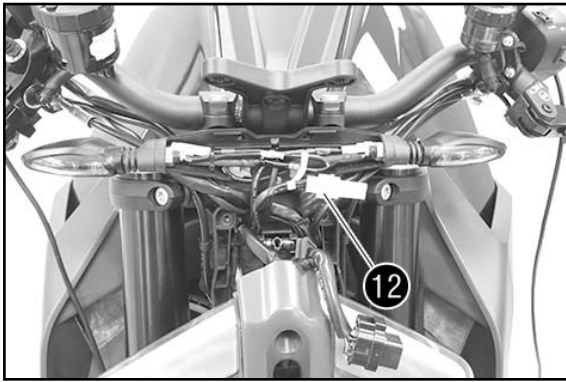

- Retirer le capuchon du connecteur 12 et le conserver.

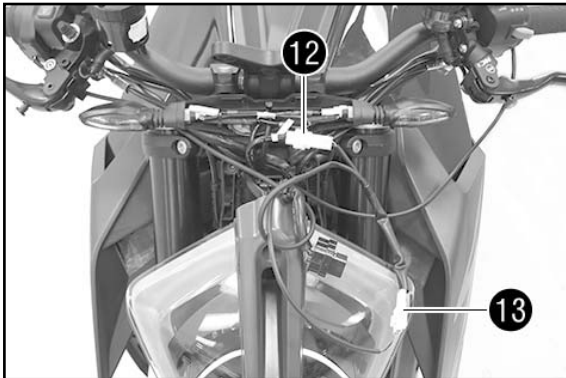

- Placer le câble des deux côtés le long des câbles déjà en place, en direction de la plaque-phare.
 - Brancher le connecteur 13 des deux poignées chauffantes.
 - Brancher le connecteur 12.

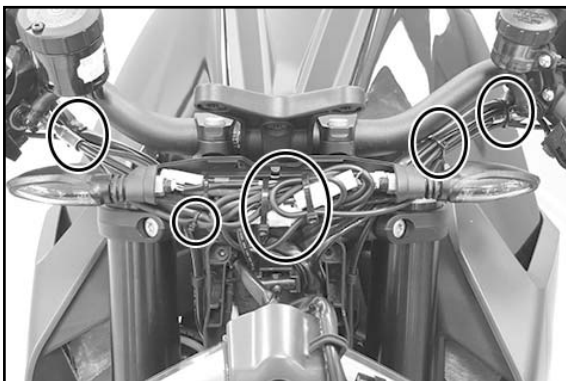

- Poser le câble de manière à ce qu'il ne soit soumis à aucune contrainte et le fixer à l'aide d'un serre-câble.

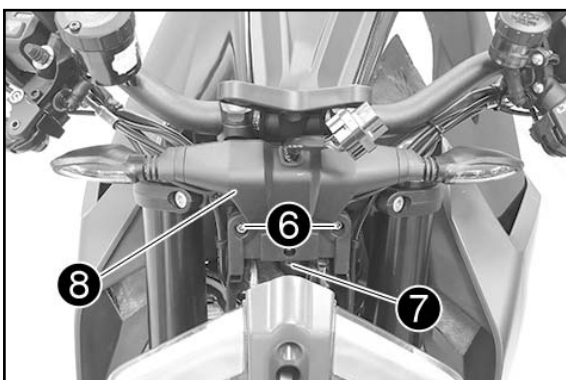

- Positionner le cache 8.

✓ Les crochets A s'engagent dans le support de clignotant.

- Mettre en place les vis d'origine 6 et les serrer à 3 Nm.

- Mettre en place la vis d'origine 7 et la serrer à 2 Nm.

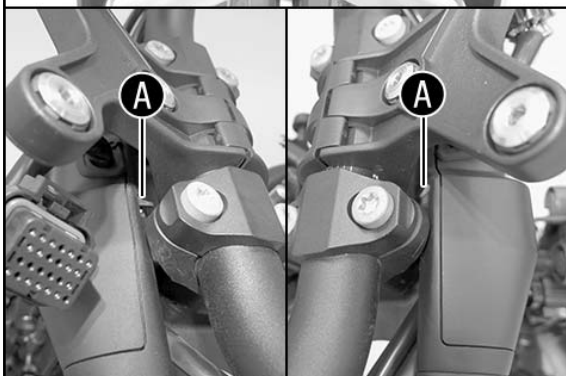

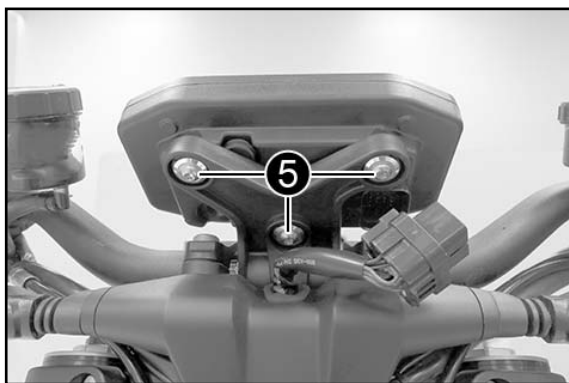

- Positionner le tableau de bord.
- Mettre les vis d'origine ⑤ et les douilles en place et les serrer à 2 Nm.

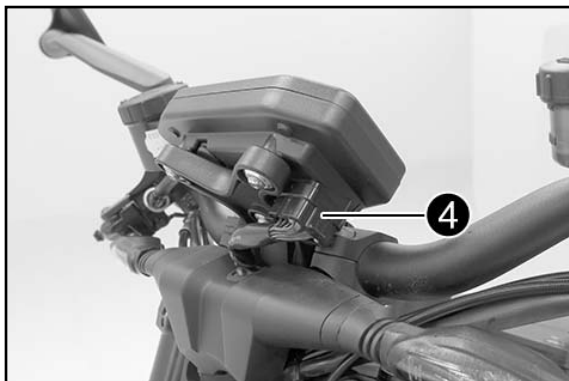

- Brancher le connecteur ④.

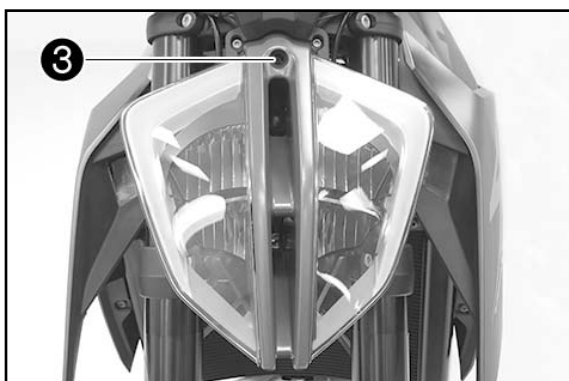

- Positionner le phare.
- Mettre en place la vis ③, mais sans la serrer.

Travaux ultérieurs

- Contrôler le réglage de l'éclairage (cf. manuel d'utilisation).
- Régler le phare (cf. manuel d'utilisation).

Utilisation

- Activer le chauffage de poignée dans le menu, sous « Options ».
- Parcourir le menu jusqu'à ce que « Chauffage de poignée » s'affiche à l'écran.
- Ouvrir le menu et sélectionner un niveau de chauffage, allumer ou éteindre les poignées chauffantes.

1290 Super Adventure R/S

Travaux préalables

- Désactiver tous les consommateurs de courant et arrêter le moteur.
- Déposer le réservoir de carburant (cf. manuel de réparation). 

REMARQUE

Les étapes de travail pour la pose des câbles sont décrites ci-après d'après un exemple où le réservoir est déposé. Il n'est cependant pas nécessaire de le déposer.

Tous les travaux accompagnés de ce symbole nécessitent des connaissances approfondies ainsi qu'un certain savoir-faire technique.



Pour la sécurité de tous, faire exécuter ces travaux par un atelier KTM agréé !

La moto y sera entretenue de manière optimale par une main d'œuvre qualifiée et disposant de l'outillage spécial nécessaire.



Montage

- Retirer la durite d'aspiration ③.

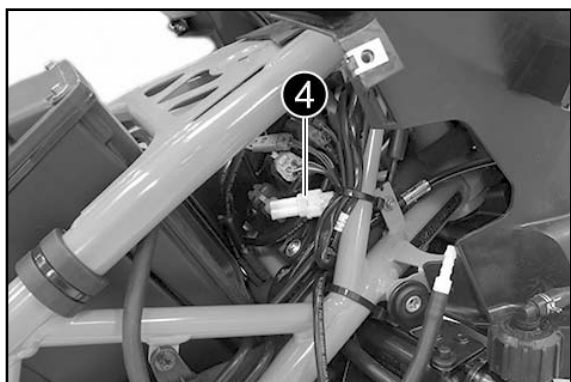

- Retirer le capuchon du connecteur ④ et le conserver.

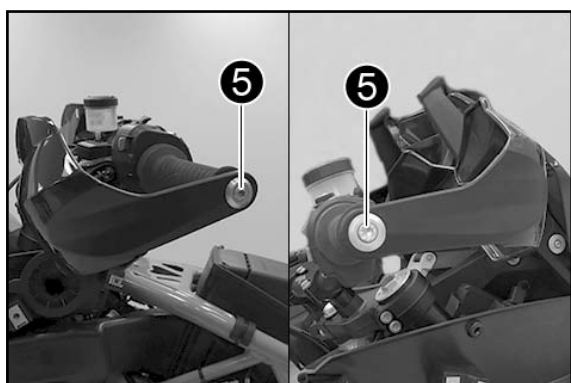

- Desserrer la vis ⑤ sur les côtés droit et gauche.
- Pousser les protections de main légèrement sur le côté.

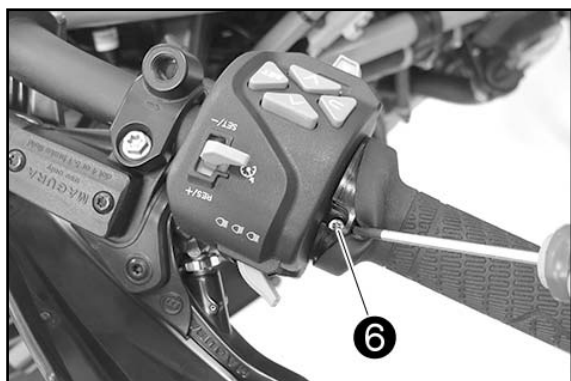

- Soulever légèrement le caoutchouc de poignée à gauche.
- Desserrer la vis ⑥.
- Retirer la poignée fixe à gauche.



- Retirer les vis 7.
- Déposer le cache.
- Dégager la poignée des gaz et le capteur de poignée d'accélération du guidon.

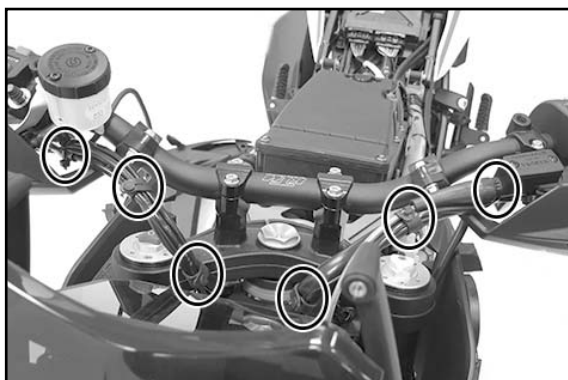

- Retirer les 6 serre-câbles indiqués.

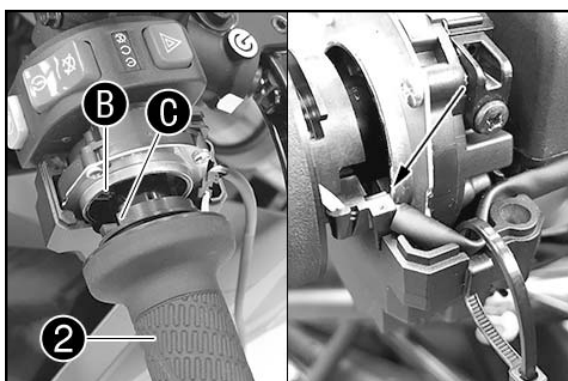

- Positionner le capteur de poignée d'accélération et la poignée chauffante droite 2 (fournie) sur le guidon.

✓ L'ergot B s'engage dans la noix d'embrayage C.

- Poser le câble du capteur de poignée d'accélération de manière à ce qu'il ne soit soumis à aucune contrainte (voir illustration) et le fixer à l'aide d'un rilsan.



- Positionner le cache.

! ATTENTION

Veiller à ce que le câble ne soit ni plié ni coincé !

- Mettre en place les vis d'origine 7 et les serrer à 3,5 Nm.

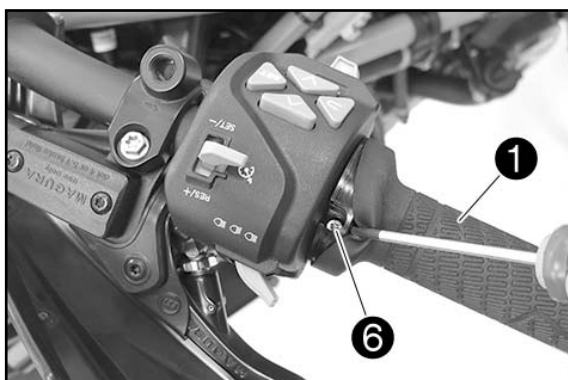

- Positionner la poignée chauffante gauche 1 (fournie) sur le guidon.
- Soulever légèrement le caoutchouc de poignée.
- Serrer la vis 6.

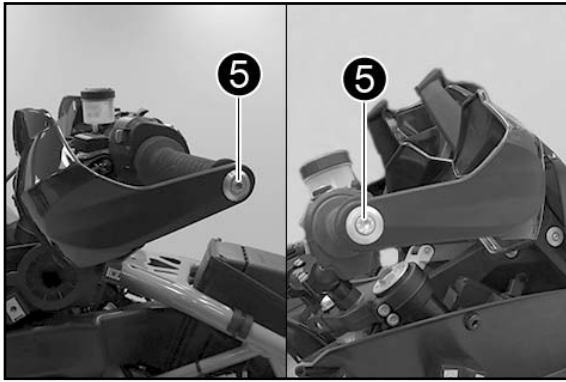

- Positionner les protections de main.
- Serrer la vis ⑤ à 15 Nm sur les côtés droit et gauche.

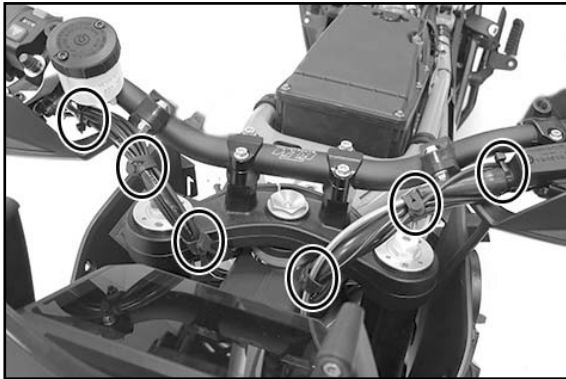

- Placer le câble des deux côtés le long des câbles déjà en place, en direction du connecteur ④ et de manière à ce qu'il ne soit soumis à aucune contrainte, puis le fixer à l'aide d'un serre-câble.

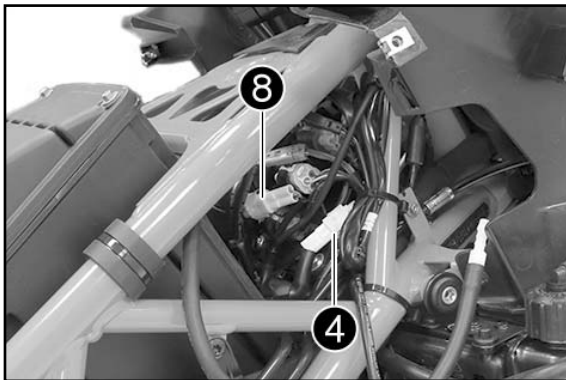

- Brancher le connecteur ⑧ des deux poignées chauffantes.
- Brancher le connecteur ④.
- Poser le câble de manière à ce qu'il ne soit soumis à aucune contrainte et le fixer à l'aide d'un serre-câble.

! ATTENTION

Veiller à ce que les câbles ne soient ni pliés ni coincés !



- Mettre la durite d'aspiration ③ en place.

Travaux ultérieurs

- Monter le réservoir de carburant (cf. manuel de réparation). 🔧

Utilisation

- Activer le chauffage de poignée dans le menu, sous « Options ».
- Parcourir le menu jusqu'à ce que « Chauffage de poignée » s'affiche à l'écran.
- Ouvrir le menu et sélectionner un niveau de chauffage, allumer ou éteindre les poignées chauffantes.



Volumen de suministro

- 1x Empuñadura térmica izquierda ❶
- 1x Empuñadura térmica derecha ❷

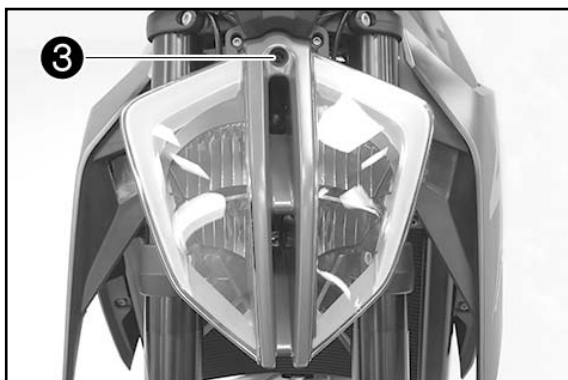

1290 Super Duke R Trabajos previos

- Desconectar todos los consumidores eléctricos y parar el motor.

Montaje

- Soltar el tornillo ❸.
- Bascular el faro hacia delante.

ADVERTENCIA

Tapar los componentes para que no resulten dañados.

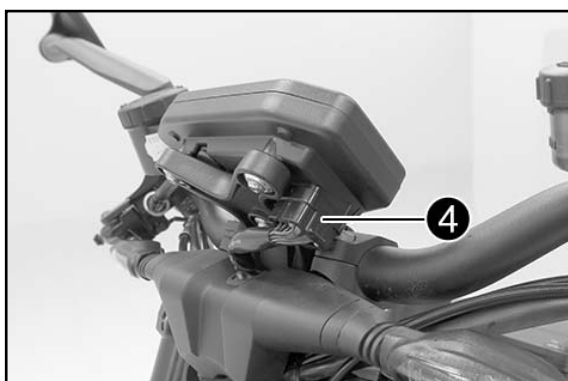

- Desenchufar el conector ❹.



- Retirar los tornillos ❺ con los casquillos.
- Quitar el cuadro de instrumentos.

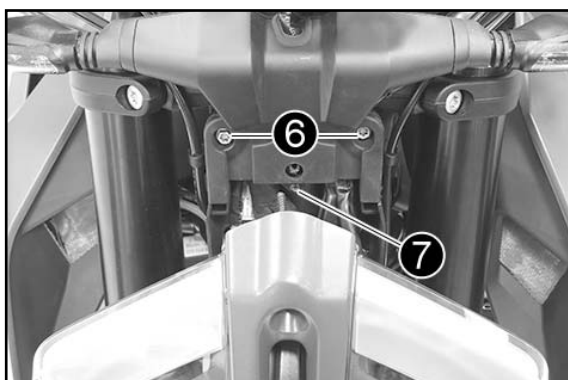

- Retirar los tornillos ❻.
- Retirar los tornillos ❼.

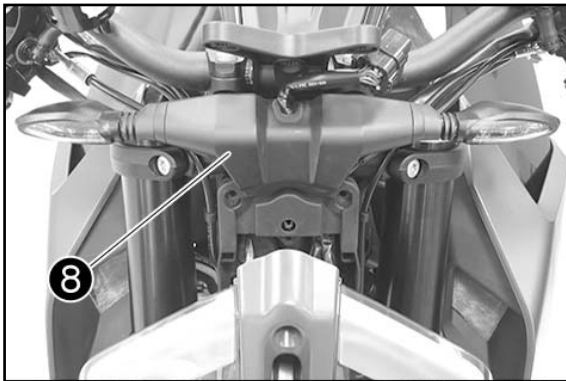

- Presionar ligeramente hacia atrás el intermitente.
- Aflojar los talones de sujeción **A** del soporte de los intermitentes.
- Retirar la cubierta **8**.

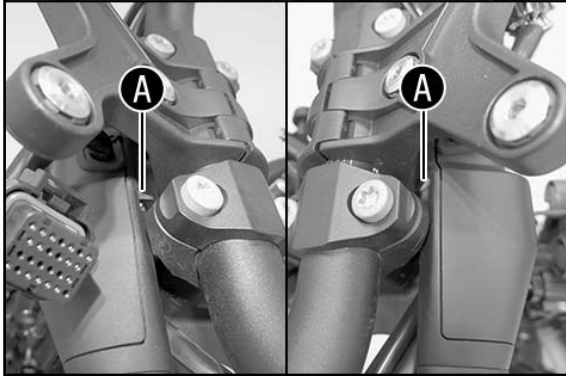

- Retirar las 5 cintas sujetacables marcadas.

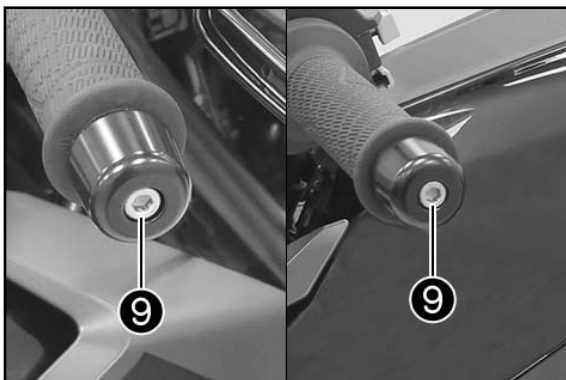

- Aflojar el tornillo **9** a ambos lados.
- Retirar el peso del manillar en ambos lados.

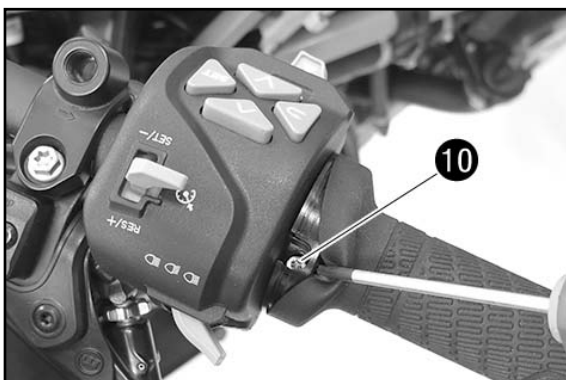

- Levantar ligeramente la empuñadura de goma izquierda.
- Aflojar el tornillo **10**.
- Retirar el puño fijo izquierdo.

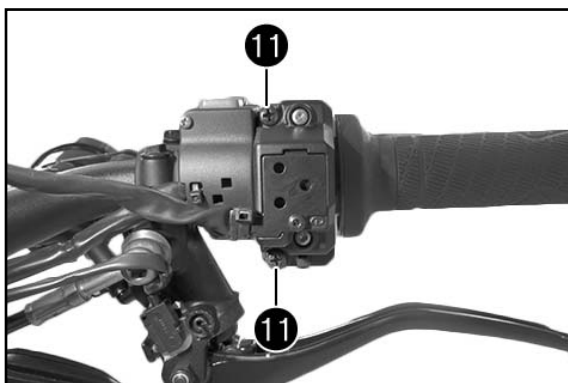

- Retirar los tornillos 11.
- Quitar la cubierta.
- Extraer el puño del acelerador y el sensor del puño del acelerador del manillar.

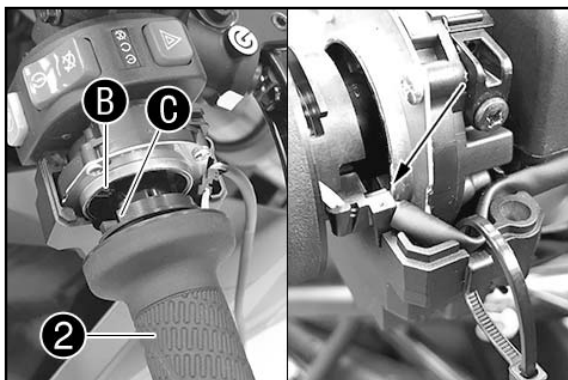

- Colocar el sensor del puño del acelerador y la empuñadura térmica derecha 2 (en el volumen de suministro) en el volante.

✓ El taló B engrana en el disco de arrastre C.

- Poser le câble du capteur de poignée d'accélération de manière à ce qu'il ne soit soumis à aucune contrainte (voir illustration) et le fixer à l'aide d'un rilsan.

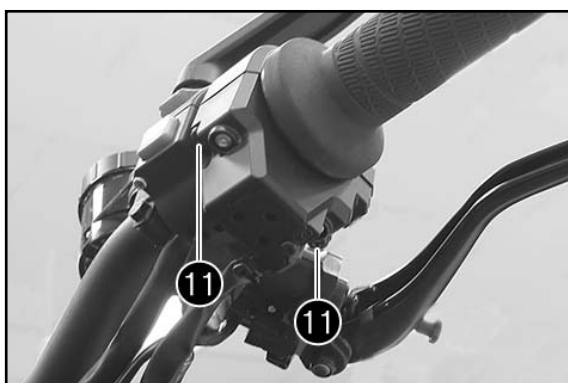

- Colocar la cubierta.

! AVISO

¡Asegurarse de que el cable no pueda retorcerse ni quedar aprisionado!

- Montar los tornillos originales 11 y apretarlos a 3,5 Nm.

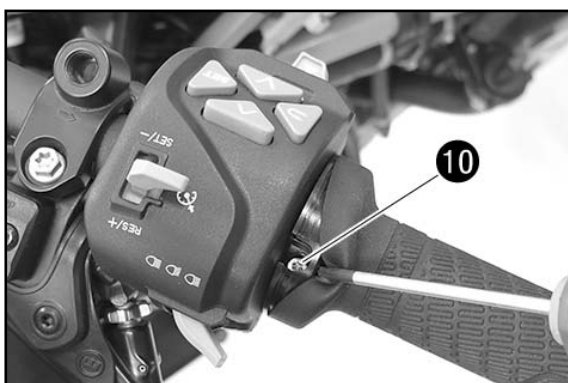

- Colocar la empuñadura térmica izquierda 1 (en el volumen de suministro) en el volante.
- Levantar ligeramente la empuñadura de goma.
- Apretar el tornillo 10.

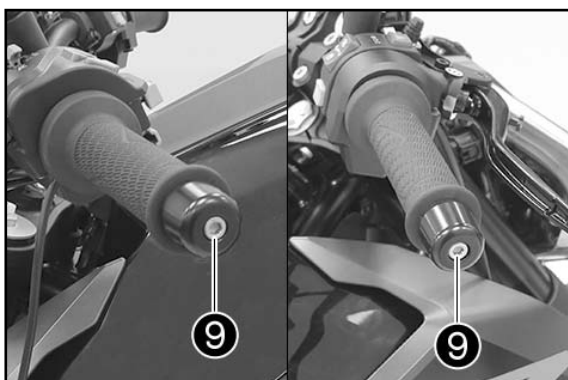

- Montar el peso del manillar en ambos lados.
- Apretar el tornillo 9 a ambos lados.

⚠ ATENCION

¡Controlar que el puño del acelerador puede girar con facilidad!

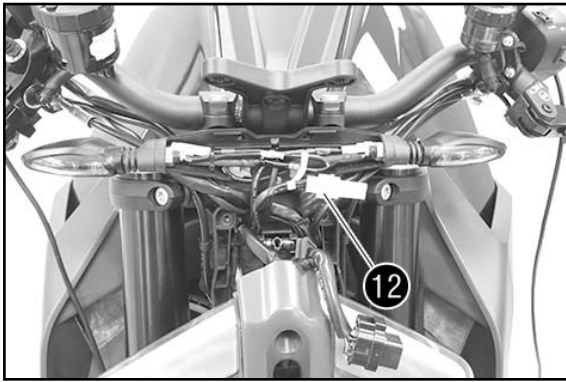

- Retirar la cubierta de protección del conector **12** y conservarla.

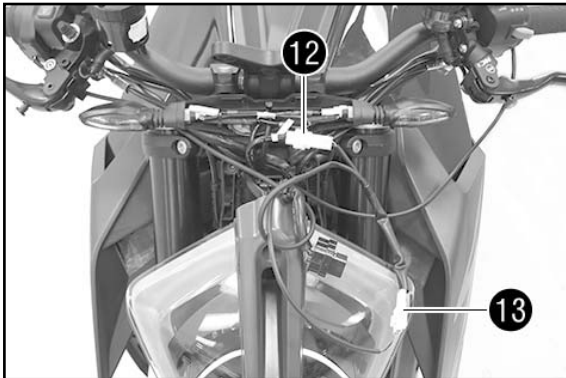

- Tender los cables hacia la cubierta del faro por ambos lados junto a los demás cables.
 - Conectar el conector **13** de ambas empuñaduras térmicas.
 - Conectar el conector **12**.

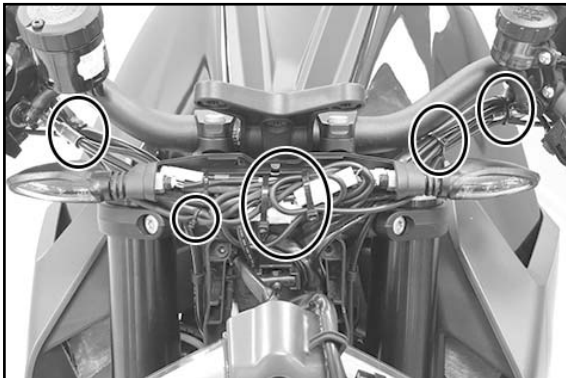

- Tender los cables sin tensiones y asegurarlos con cinta sujetacables.

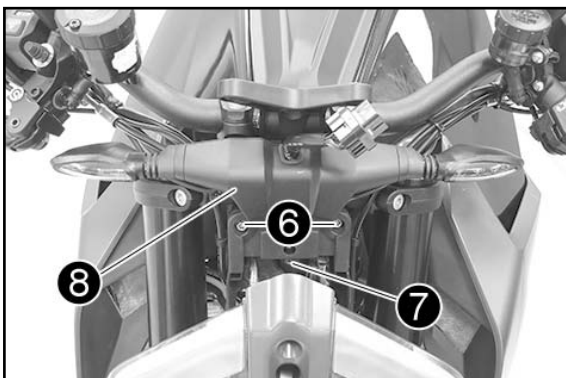

- Colocar la cubierta **8**.

✓ Insertar los talones de sujeción **A** en el soporte de los intermitentes.

- Montar los tornillos originales **6** y apretarlos a 3 Nm.
 - Montar el tornillo original **7** y apretarlo a 2 Nm.

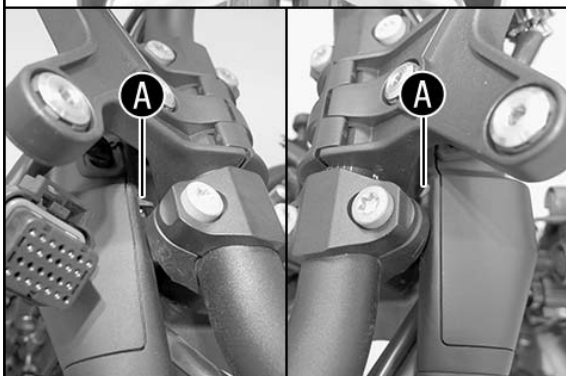

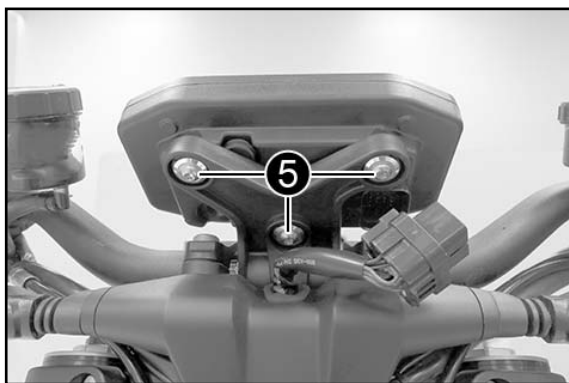

- Colocar el cuadro de instrumentos.
- Montar los tornillos originales ⑤ con los casquillos y apretarlos a 2 Nm.

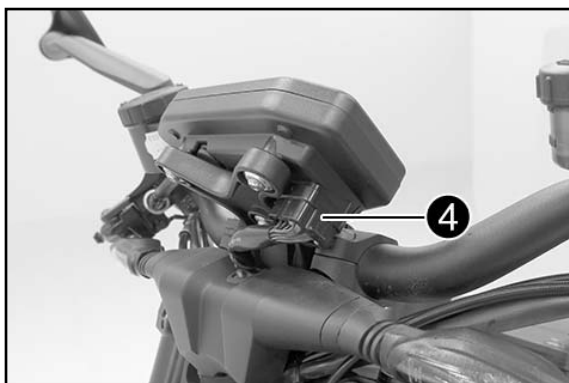

- Enchufar el conector ④.

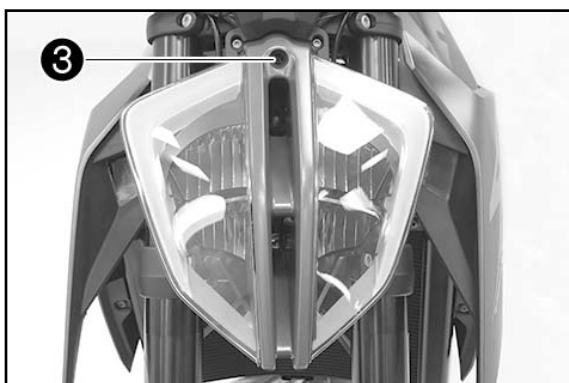

- Colocar el faro.
- Montar el tornillo ③, pero no apretarlo todavía.

Trabajos posteriores

- Controlar el ajuste del equipo de luces (ver manual de instrucciones).
- Ajustar los faros (ver manual de instrucciones).

Utilisation

- Activer le chauffage de poignée dans le menu, sous « Options ».
- Parcourir le menu jusqu'à ce que « Chauffage de poignée » s'affiche à l'écran.
- Abrir el menú y seleccionar un nivel de calefacción o conectar y desconectar las empuñaduras térmicas.

1290 Super Adventure R/S

Trabajos previos

- Desconectar todos los consumidores eléctricos y parar el motor.
- Desmontar el depósito de combustible (ver el manual de reparación). 

REMARQUE

Les étapes de travail pour la pose des câbles sont décrites ci-après d'après un exemple où le réservoir est déposé. Il n'est cependant pas nécessaire de le déposer.

Todas las tareas marcadas con este símbolo requieren conocimientos especiales y capacidad de comprensión técnica. ¡Por su seguridad, le aconsejamos que acuda a un taller especializado autorizado de Husqvarna Motorcycles para llevar a cabo estas tareas!





Estos talleres cuentan con mecánicos que han recibido una instrucción específica y disponen de las herramientas especiales necesarias para realizar el mantenimiento ideal de su motocicleta.



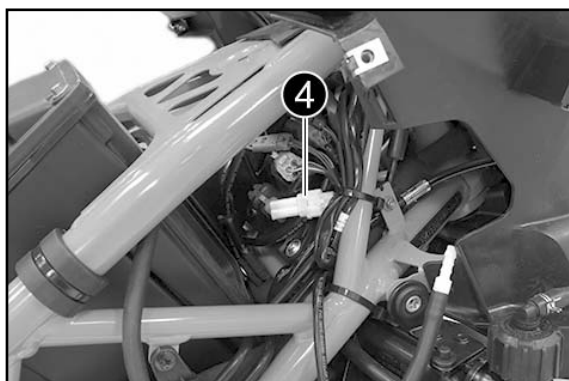

Montaje

- Retirar el esnórquel de aspiración .

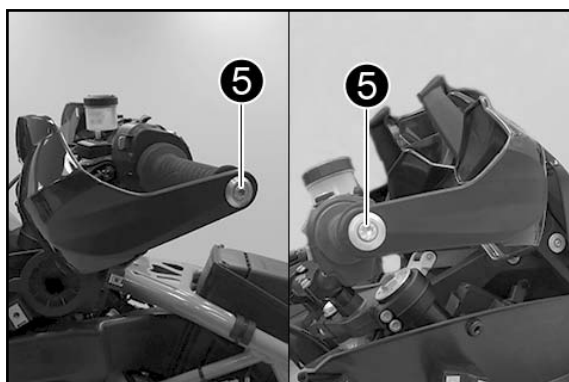

- Retirar la cubierta de protección del conector  y conservarla.



- Aflojar el tornillo  a ambos lados.
- Presionar los guardamanos ligeramente hacia un lado.

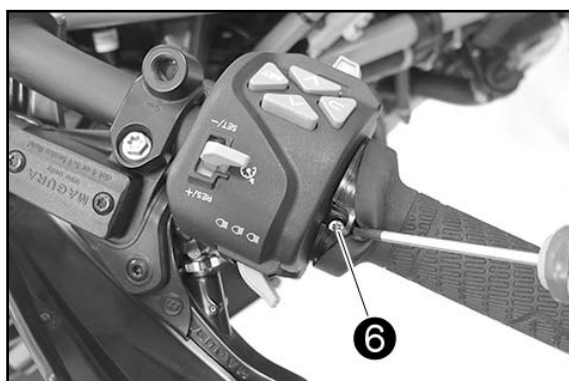

- Levantar ligeramente la empuñadura de goma izquierda.
- Soltar el tornillo .
- Retirar el puño fijo izquierdo.



- Retirar los tornillos 7.
- Quitar la cubierta.
- Extraer el puño del acelerador y el sensor del puño del acelerador del manillar.

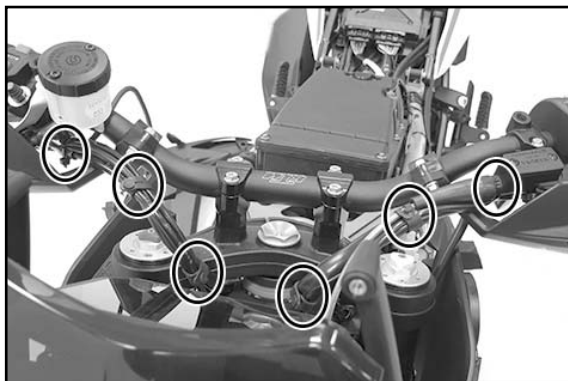

- Retirar las 6 cintas sujetacables marcadas.

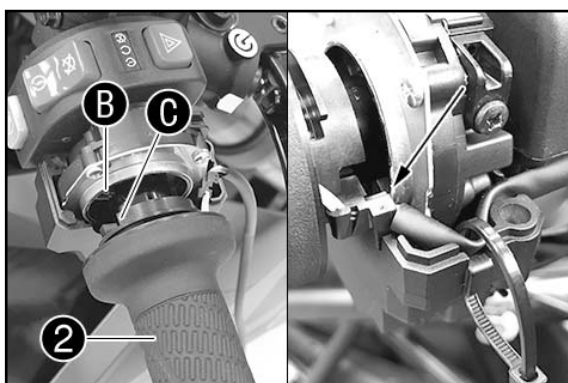

- Colocar el sensor del puño del acelerador y la empuñadura térmica derecha 2 (en el volumen de suministro) en el volante.

✓ El taló B engrana en el disco de arrastre C.

- Poser le câble du capteur de poignée d'accélération de manière à ce qu'il ne soit soumis à aucune contrainte (voir illustration) et le fixer à l'aide d'un rilsan.



- Colocar la cubierta.

! AVISO

¡Asegurarse de que el cable no pueda retorcerse ni quedar aprisionado!

- Montar los tornillos originales 7 y apretarlos a 3,5 Nm.

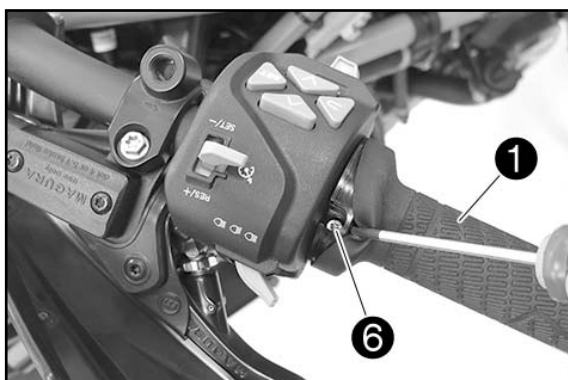

- Colocar la empuñadura térmica izquierda 1 (en el volumen de suministro) en el volante.
- Levantar ligeramente la empuñadura de goma.
- Apretar el tornillo 6.

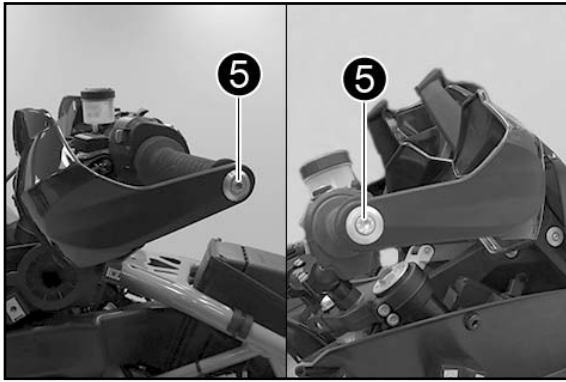

- Colocar los guardamanos.
- Apretar el tornillo 5 a 15 Nm en ambos lados.

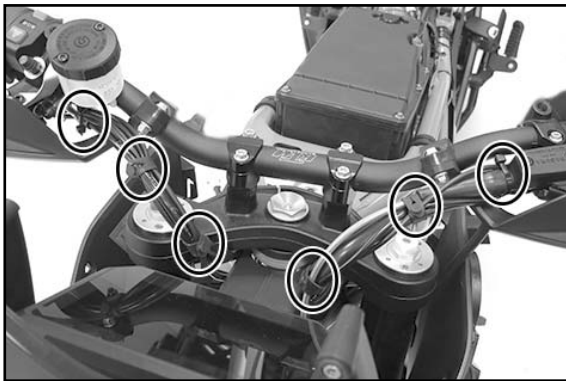

- Tender los cables sin tensión hacia el conector 4 por ambos lados junto a los demás cables y asegurarlos con cintas sujetacables.

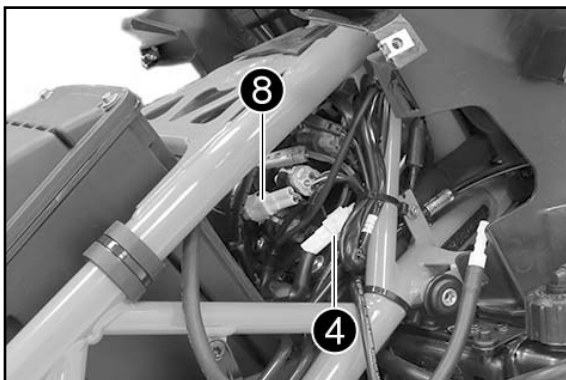

- Conectar el conector 3 de ambas empuñaduras térmicas.
- Enchufar el conector 4.
- Tender los cables sin tensiones y asegurarlos con cinta sujetacables.

! AVISO

¡Asegurarse de que los cables no puedan retorcerse ni quedar aprisionados!



- Montar el esnórquel de aspiración 3.

Trabajos posteriores

- Montar el depósito de combustible (ver el manual de reparación). 🛠️

Utilisation

- Activer le chauffage de poignée dans le menu, sous « Options ».
- Parcourir le menu jusqu'à ce que « Chauffage de poignée » s'affiche à l'écran.
- Ouvrir le menu et sélectionner un niveau de chauffage ou connecter et déconnecter les empuñaduras térmiques.