

KTM POWERPARTS **INFORMATION**

LED INDICATOR KIT



64114937044

04.2018
3.213.954



KTM Sportmotorcycle GmbH
5230 Mattighofen, Austria
www.ktm.com



3 DEUTSCH

Wir freuen uns, dass Sie sich für dieses Produkt entschieden haben.

Unser hochwertiges Qualitätsprodukt ist rennerprobt und wurde speziell für sportliche Herausforderungen entwickelt. Eine korrekte Montage des Produktes ist unerlässlich, um ein Maximum an Sicherheit und Funktionalität gewährleisten zu können. Bitte befolgen Sie daher die Montageanleitung oder wenden Sie sich an Ihren autorisierten Fachhändler.

Für falsche Montage oder Verwendung dieses Produktes kann der (Quasi-)Hersteller bzw. Lieferant nicht zur Verantwortung gezogen werden.
Vielen Dank.

9 ENGLISH

Thank you for choosing this product.

Our high quality product has been tested under racing conditions and was developed specifically for use in sports activities. Correct installation of the product is essential to ensure that a maximum degree of safety and functionality is achieved. Therefore, please follow the installation instructions or contact your authorized dealer.

The (quasi) manufacturer or supplier cannot be held responsible for products that are incorrectly mounted or inappropriately used.
Thank you.

15 ITALIANO

Grazie per aver scelto questo prodotto.

Questo nostro prodotto di pregiata qualità è collaudato nelle competizioni ed è stato sviluppato specificamente per gare sportive. Il montaggio corretto del prodotto è fondamentale per garantirne la massima sicurezza e funzionalità. Rispetti quindi le istruzioni di montaggio o rivolgerti al proprio concessionario autorizzato.

Il produttore (detentore del marchio)/fornitore non può essere considerato responsabile per un montaggio o impiego errato del presente prodotto.
Vi ringraziamo per l'attenzione!

21 FRANÇAIS

Merci d'avoir porté votre choix sur ce produit.

Notre produit de haute qualité est éprouvé pour les compétitions et a été conçu spécialement pour un usage sportif. Un montage approprié du produit est indispensable pour garantir une sécurité et une fonctionnalité maximales du véhicule. C'est pourquoi nous vous invitons à suivre scrupuleusement le manuel de montage ou à vous adresser à votre revendeur agréé.

En cas de montage ou d'utilisation non conformes de ce produit, le (quasi) constructeur ou le fournisseur déclinent toute responsabilité.
Merci !

27 ESPAÑOL

Le agradecemos que se haya decidido por este producto.

Este producto de alta calidad está probado para la competición y se ha desarrollado específicamente para las exigencias de este deporte. Para poder garantizar los máximos niveles de seguridad y funcionalidad, es imprescindible que el producto se monte correctamente. Por este motivo, es muy importante que siga las instrucciones del manual de montaje o que se ponga en contacto con su concesionario autorizado.

El (cuasi) fabricante y el proveedor de este producto no se harán responsables del montaje y el uso incorrectos.
¡Muchas gracias!

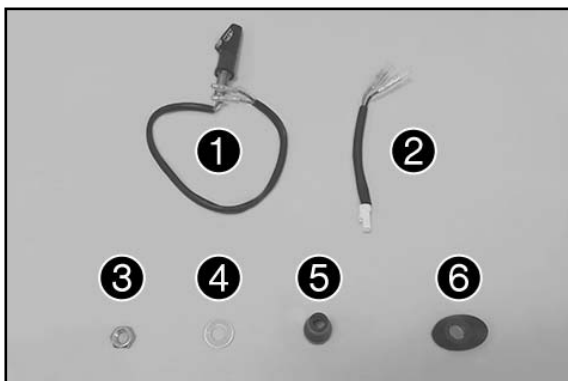

Lieferumfang

- 1x Blinker ❶
- 1x Widerstand ❷
- 1x Mutter ❸
- 1x Scheibe ❹
- 1x Schutzkappe ❺
- 1x Blinkeradapter ❻

Blinker vorn

Montage

- Zündung ausschalten.
- Schrauben ❷ entfernen.

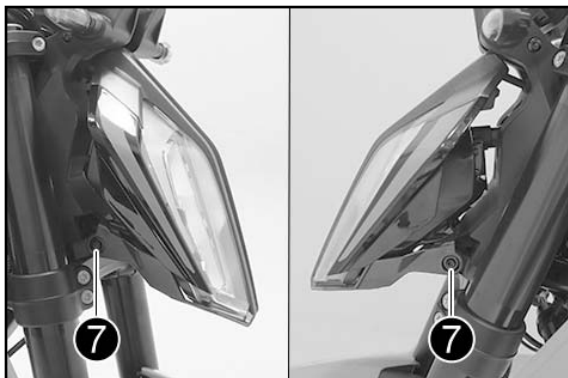

- Einstellschraube ❸ komplett herausdrehen.

HINWEIS

Die Einstellschraube ist durch eine Kugelkopfhalterung an der Scheinwerfermaske befestigt.
Die Einstellschraube nicht aus der Kugelkopfhalterung ziehen.

- Scheinwerfermaske leicht nach vorn schwenken und Stecker ❹ abstecken.
- Scheinwerfer abnehmen.

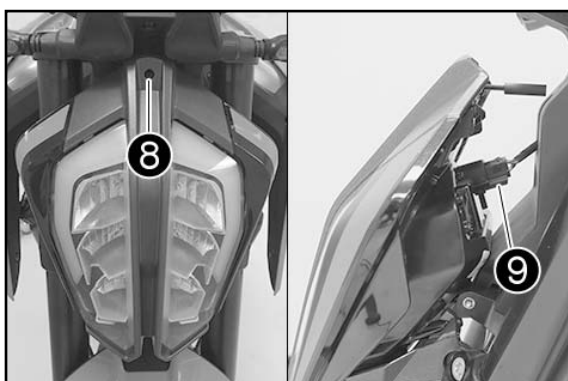

- Schrauben ❿ entfernen.
- Schrauben ⓫ entfernen.
- Schrauben ⓬ entfernen.

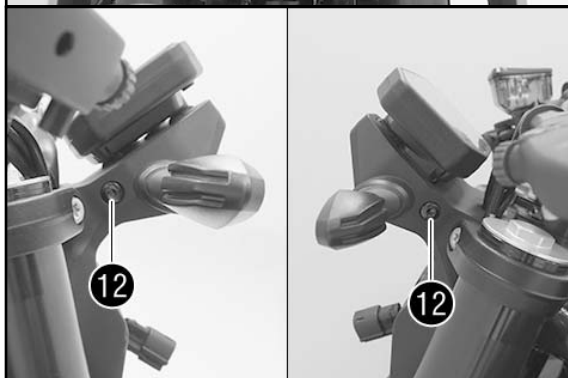
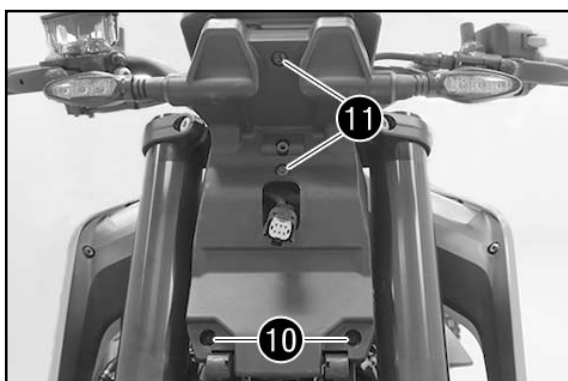

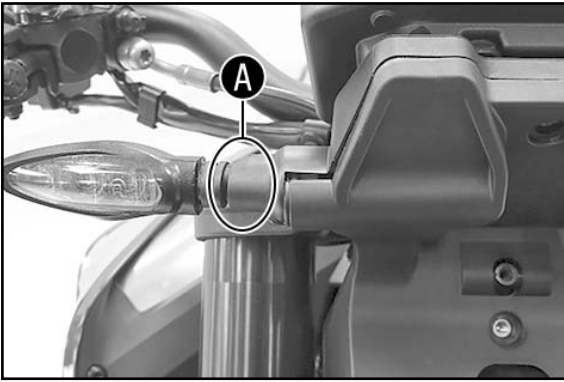

- Blinker im Bereich **A** greifen und vorsichtig entgegen der Fahrtrichtung drücken.

✓ Die Abdeckung löst sich wie im Bild ersichtlich.

- Arbeitsschritt auf der gegenüberliegenden Seite wiederholen.
- Abdeckung entfernen.

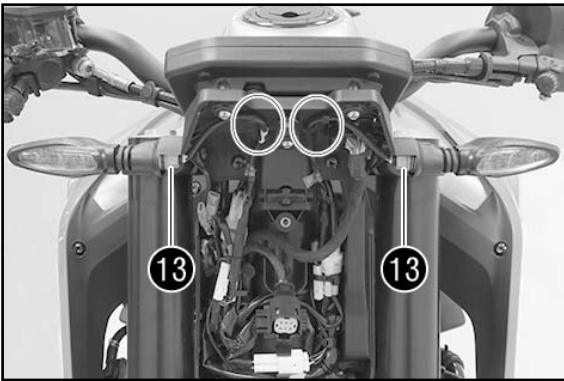

- Muttern **13** komplett vom Gewinde lösen.
- Blinkerkabel aus den Halterungen oben entfernen.

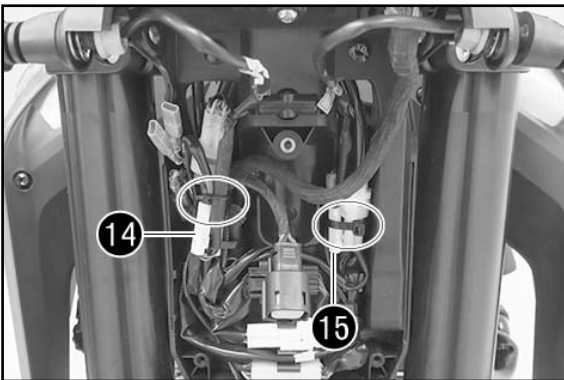

- Kabelbinder entfernen.
- Blinker-Steckerverbindungen rechts **14** und links **15** trennen.
- Blinker mit Muttern und Scheiben entfernen.

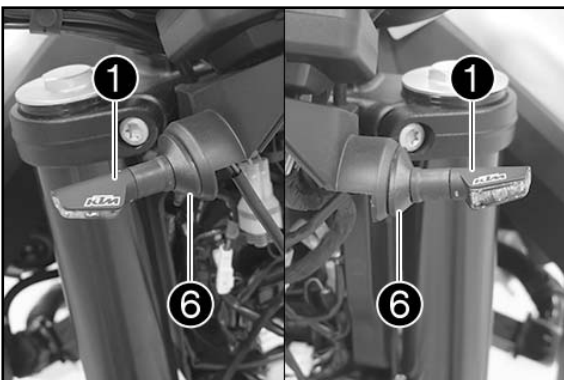

- Blinkeradapter **6** (Lieferumfang) am Blinker **1** (Lieferumfang) vormontieren.

- Blinker **1** (Lieferumfang) einfädeln und mit Blinkeradapter **6** positionieren.

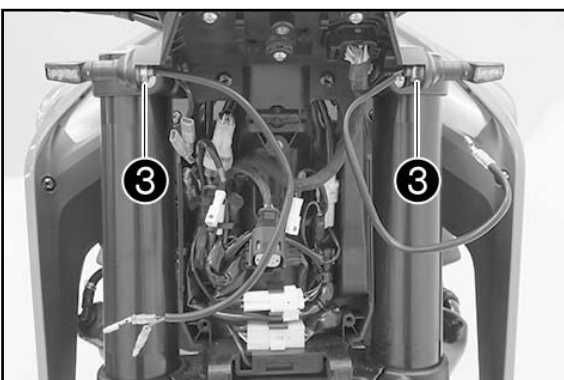

- Muttern **3** mit Scheiben **4** (alles Lieferumfang) montieren und festziehen.

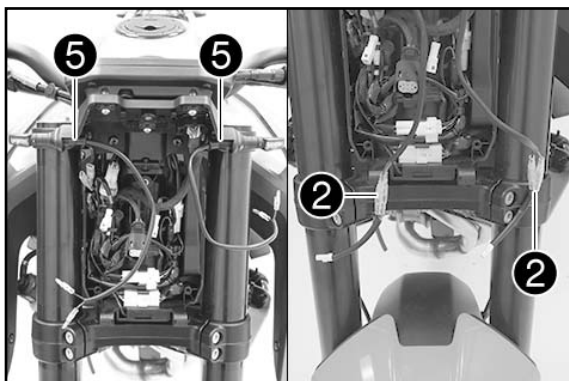

- Schutzkappen 5 (Lieferumfang) montieren.
- Widerstände 2 (Lieferumfang) entsprechend der Farben anstecken.

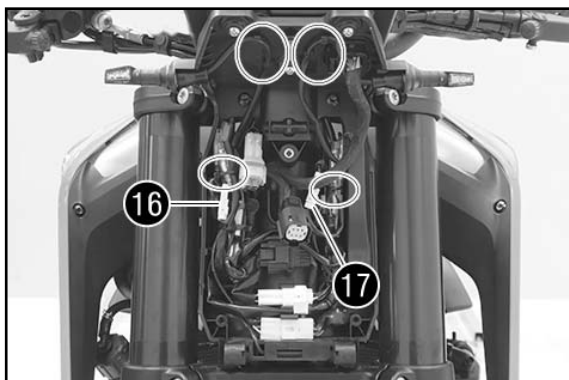

- Blinker-Steckerverbindungen 16 und 17 zusammenstecken.
- Blinkerkabel in den Halterungen oben montieren.
- Alle Kabel spannungsfrei verlegen und mit Kabelbinder sichern.

! VORSICHT

Sicher stellen, dass das Kabel nicht geknickt oder geklemmt werden kann!

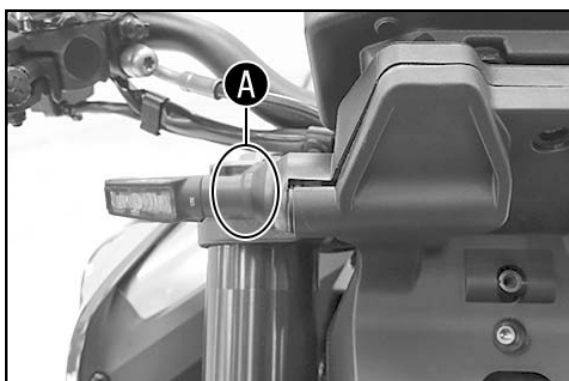

- Abdeckung positionieren, dabei die Steckerverbindung des Scheinwerfers durch die Öffnung führen.
- Blinker im Bereich A greifen und vorsichtig entgegen der Fahrtrichtung drücken, gleichzeitig die Abdeckung festdrücken.

✓ Abdeckung rastet mit einem hörbaren Klicken ein.

- Arbeitsschritt auf der gegenüberliegenden Seite wiederholen.

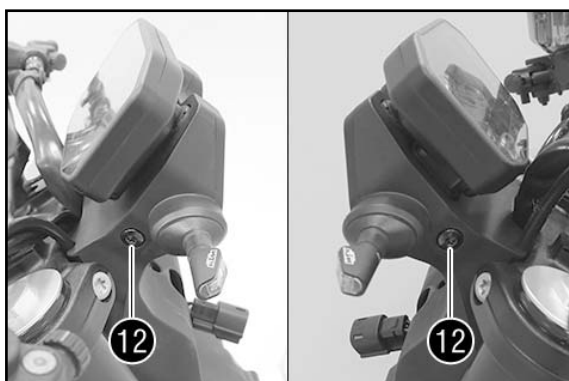

- Schrauben 12 montieren und mit 5 Nm festziehen.
- Schrauben 11 montieren und mit 5 Nm festziehen.
- Schrauben 10 montieren und mit 2 Nm festziehen.

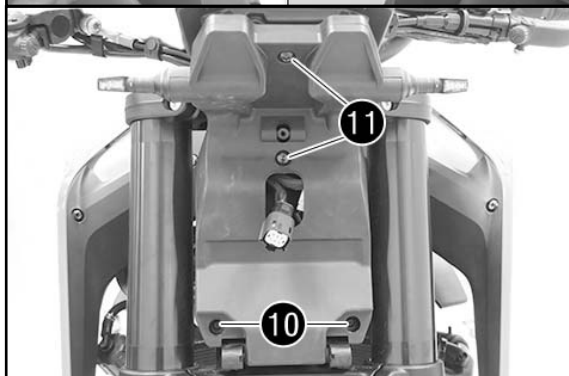

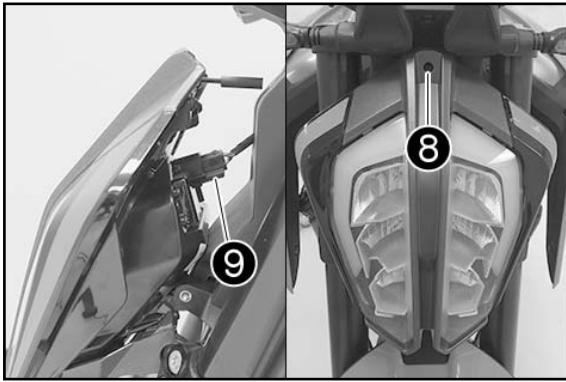

- Stecker 9 anstecken.
- Scheinwerfermaske positionieren.
- Einstellschraube 8 montieren.

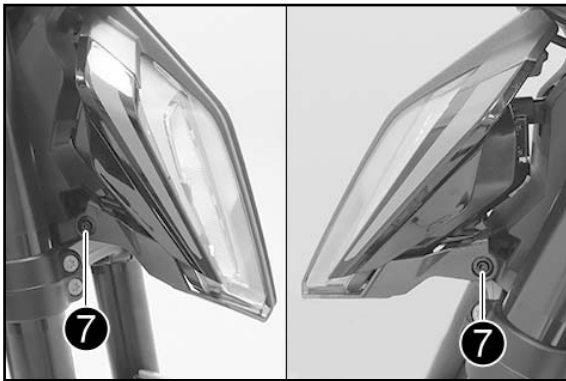

- Schrauben 7 montieren und mit 2 Nm festziehen.

Nacharbeit

- Scheinwerfereinstellung kontrollieren (s. Bedienungsanleitung).
- Leuchtweite des Scheinwerfers einstellen (s. Bedienungsanleitung).
- Funktion der Beleuchtung kontrollieren.

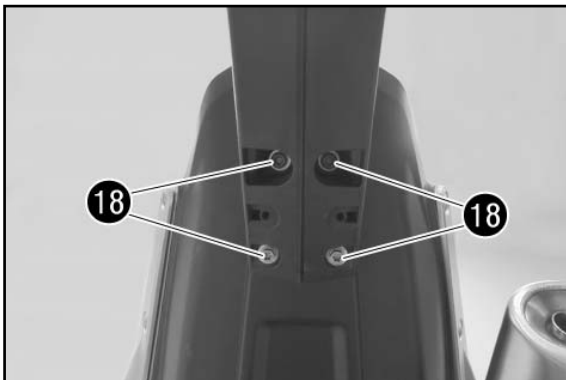

Blinker hinten

Montage

- Schrauben 18 entfernen.
- Kennzeichenträger auf dem Hinterrad ablegen.

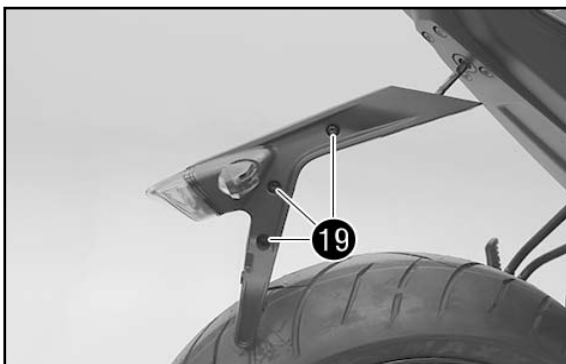

- Schrauben 19 entfernen.
- Kennzeichenträgerhälften nach außen schwenken und im Bereich B aushängen.
- Rücklicht auf dem Hinterrad ablegen.

HINWEIS

Nach Bedarf kann der komplette Kennzeichenträger entfernt werden. Dafür unter der Soziussitzbank den entsprechenden Stecker abstecken und das Kabel mit Gummitülle ausfädeln.

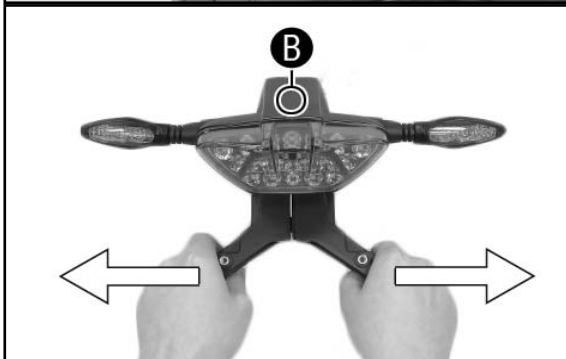

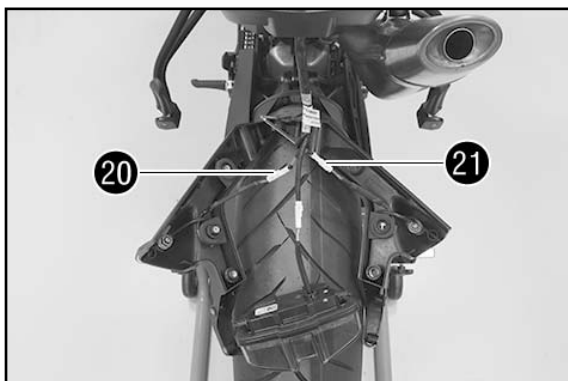

- Blinker-Steckerverbindung 20 und 21 trennen.
- Kennzeichenträgerhälften abnehmen.

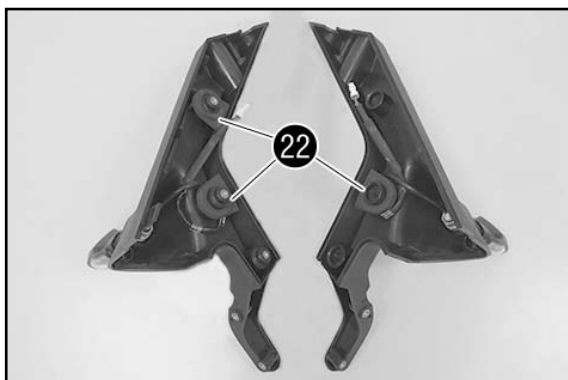

- Kabelhalter 22 entfernen.

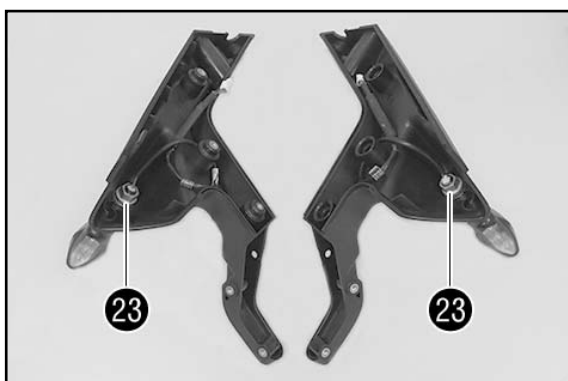

- Muttern 23 mit Scheiben entfernen.
- Blinker entfernen.

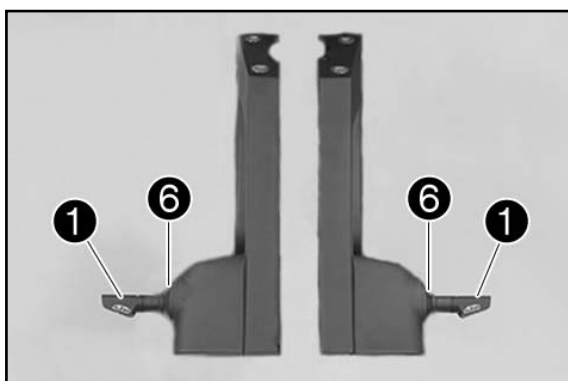

- Blinkeradapter 6 (Lieferumfang) am Blinker 1 (Lieferumfang) vormontieren.
- Blinker 1 (Lieferumfang) einfädeln und mit Blinkeradapter 6 positionieren.

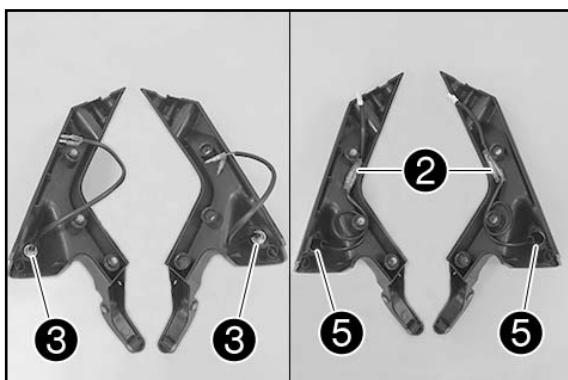

- Muttern 3 mit Scheiben 4 (alles Lieferumfang) montieren und festziehen.
- Schutzkappen 5 (Lieferumfang) montieren.
- Widerstände 2 (Lieferumfang) entsprechend der Farben anstecken.
- Kabel positionieren.

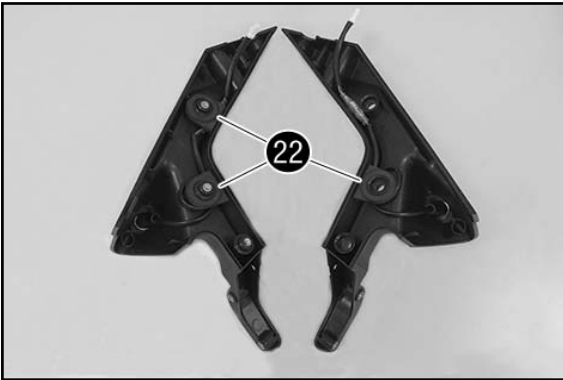

- Kabelhalter 22 mit der Lippe C nach innen montieren.

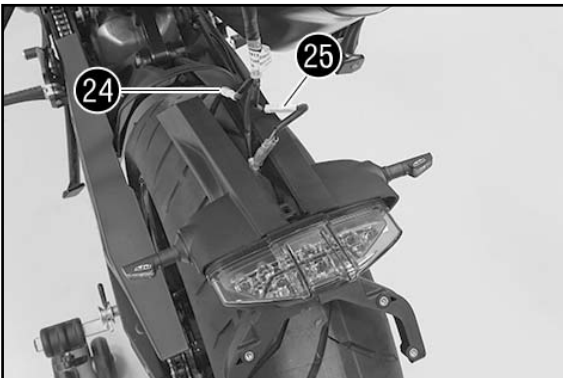
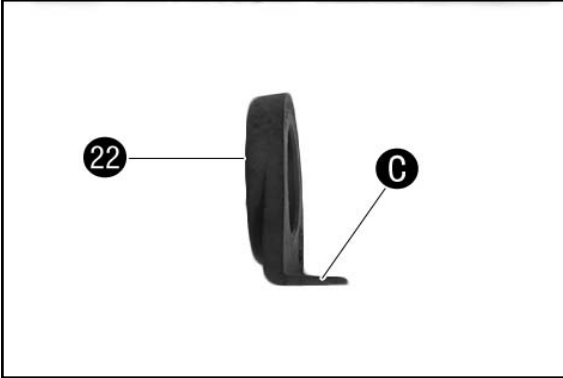

- Blinker-Steckerverbindung 24 und 25 zusammenstecken.
 - Kennzeichenträgerhälften am Rücklicht positionieren.
 - Kabel spannungsfrei verlegen.

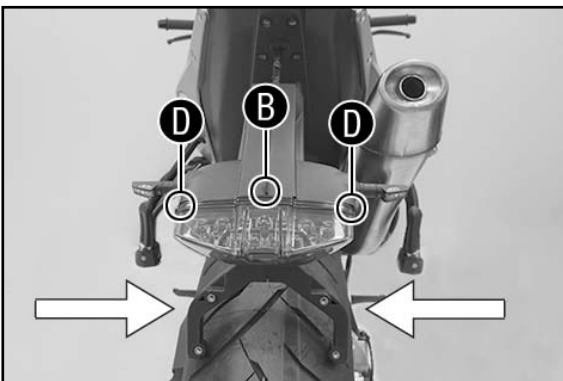

- Die Kennzeichenträgerhälften im Bereich B einrasten und das Rücklicht in den Bereichen D einhängen.
 - Kennzeichenträgerhälften zusammenstecken.

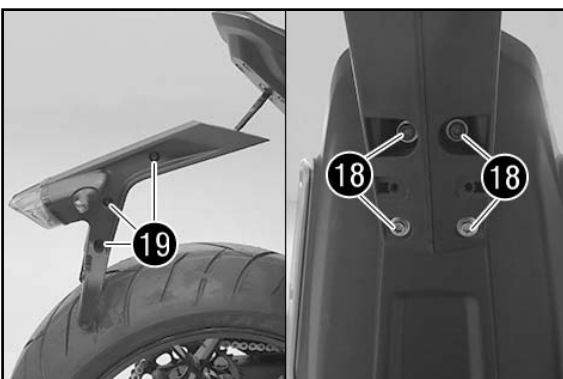

- Schrauben 19 montieren und mit 5 Nm festziehen.
 - Kennzeichenträger positionieren.
 - Schrauben 18 montieren und mit 10 Nm (Loctite 243) festziehen.

Nacharbeit

- Funktion der Beleuchtung kontrollieren.

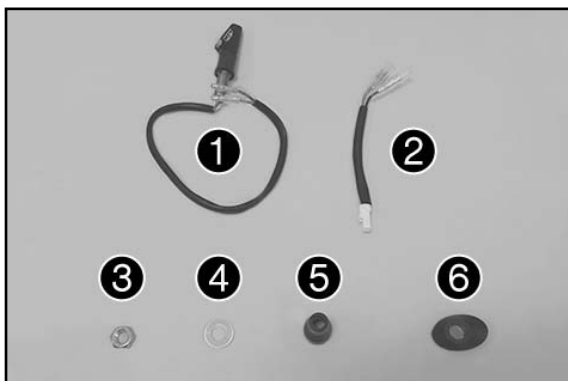

Scope of supply

- 1x turn signal ①
- 1x resistance ②
- 1x nut ③
- 1x washer ④
- 1x protection cap ⑤
- 1x turn signal adapter ⑥

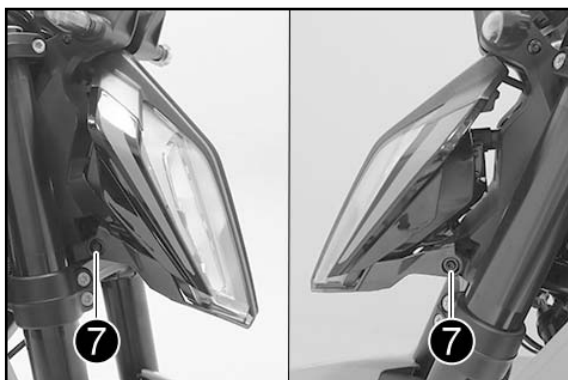

Front turn signal

Assembly

- Switch off the ignition system.
- Remove screws ⑦.

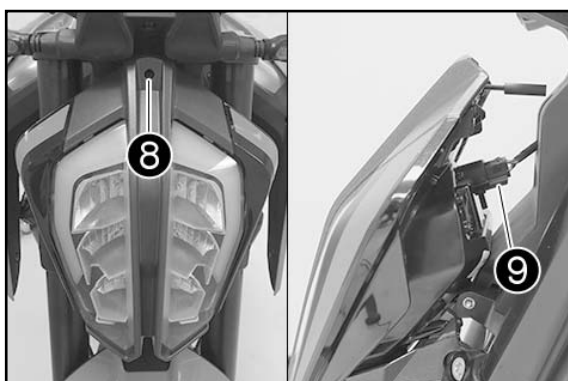

- Completely unscrew adjusting screw ⑧.

NOTE

The adjusting screw is fastened to the headlight mask by a ball head holder.
Do not pull the adjusting screw out of the ball head adjuster.

- Swivel the headlight mask slightly forwards and disconnect socket connector ⑨.
- Take off the headlight.

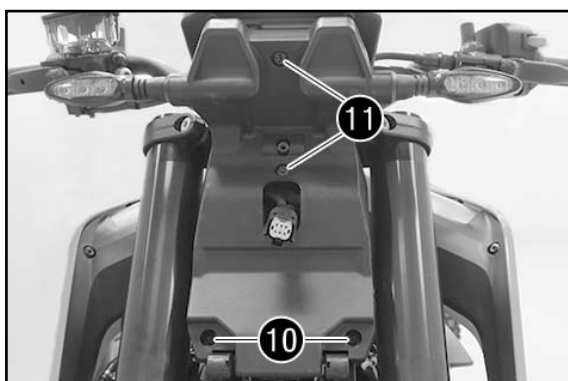

- Remove screws ⑩.
- Remove screws ⑪.
- Remove screws ⑫.

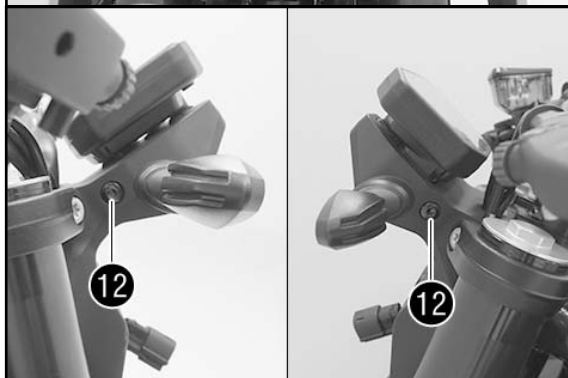

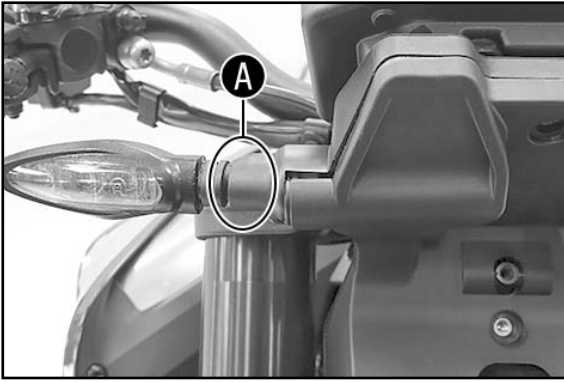

- Hold turn signal in area **A** and carefully press against the direction of travel.

✓ The cover is detached as illustrated.

- Repeat the operation on the opposite side.
- Remove the cover.

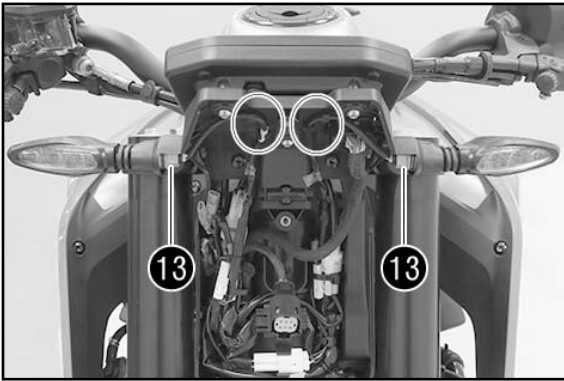

- Loosen nuts **13** fully from thread.
- Remove turn signal cable from the attachment at the top.

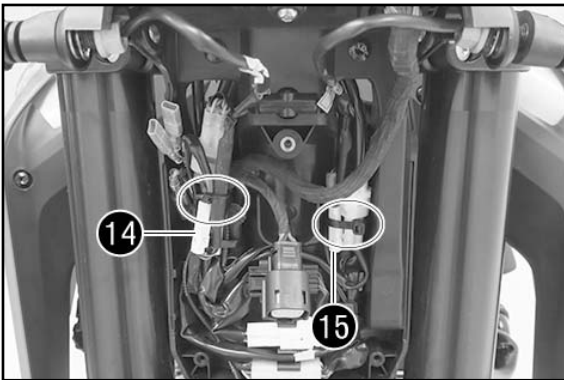

- Remove the cable tie.
- Disconnect turn signal plug-in connectors on the right **14** and left **15**.
- Remove turn signal with nuts and washers.

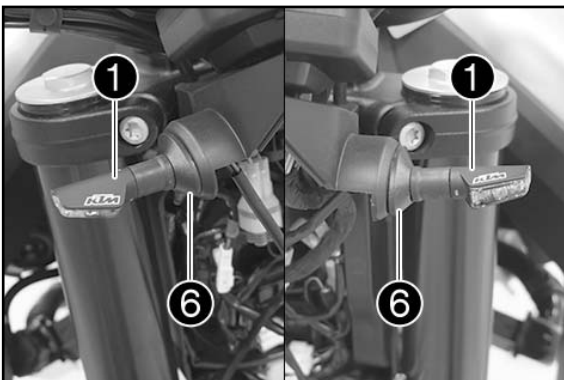

- Preassemble turn signal adapter **6** (included) on the turn signal **1** (included).
- Thread in turn signal **1** (included) and position turn signal adapter **6**.

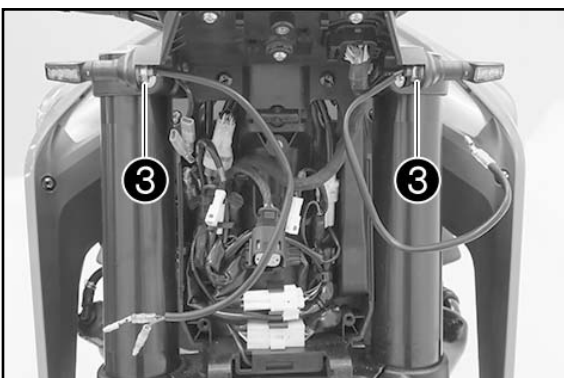

- Mount nuts **3** with washers **4** (all included) and tighten.

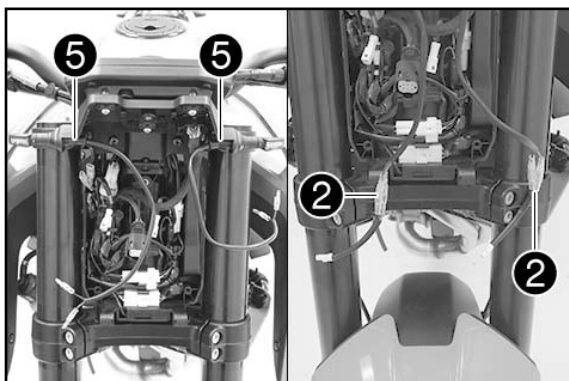

- Mount protection caps 5 (included).
- Plug in resistances 2 (included) according to the colors.

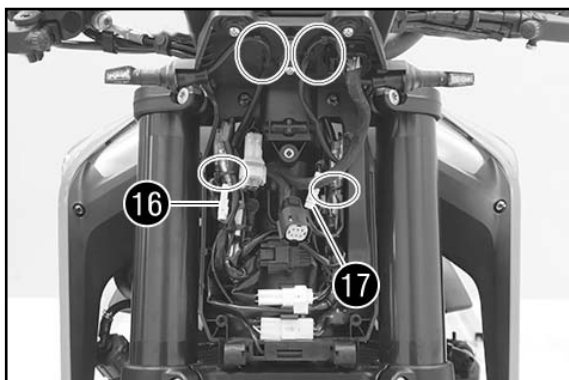

- Join turn signal plug-in connectors 16 and 17.
- Mount turn signal cable in the brackets at the top.
- Route all cables without tension and secure with a cable tie.

! ATTENTION

Ensure that the cable can neither be kinked or pinched!

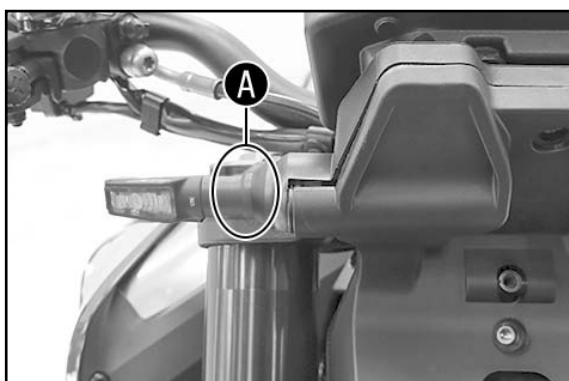

- Position cover, guiding the headlight plug-in connector through the opening in the process.
- Hold turn signal in the area A and carefully press against the direction of travel, while pressing the cover tight at the same time.

✓ The cover engages with an audible click.

- Repeat the operation on the opposite side.

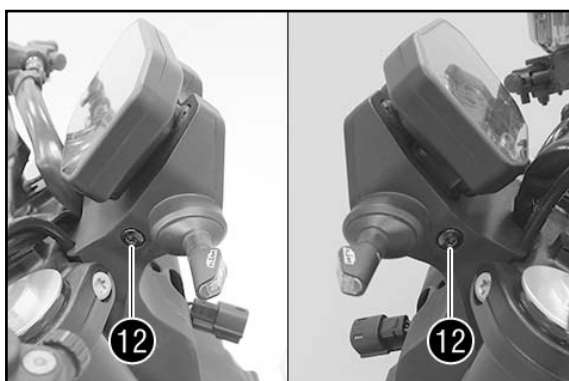

- Mount screws 12 and tighten to 5 Nm.
- Mount screws 11 and tighten to 5 Nm.
- Mount screws 10 and tighten to 2 Nm.

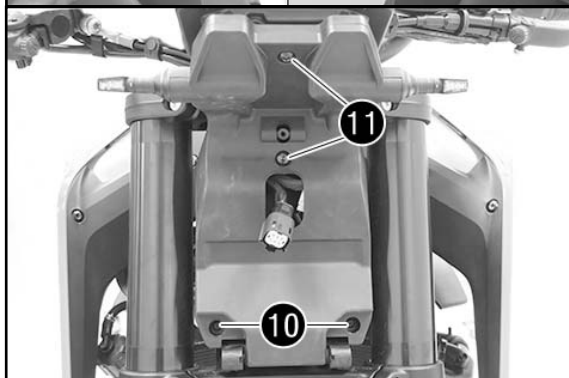

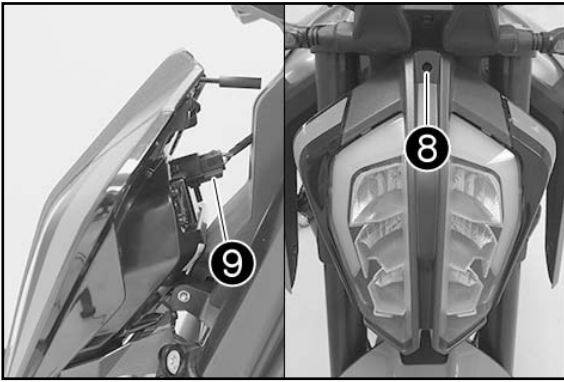

- Plug in connector 9.
- Position the headlight mask.
- Mount adjusting screw 8.

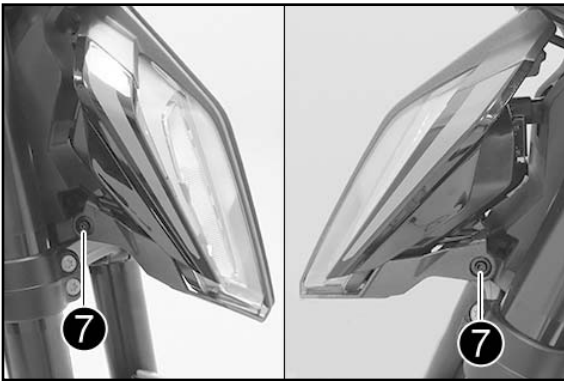

- Mount screws 7 and tighten to 2 Nm.

Final steps

- Check headlight setting (see Owner's Manual).
- Adjust headlight range of the headlight (see Owner's Manual).
- Check that the lighting is functioning properly.

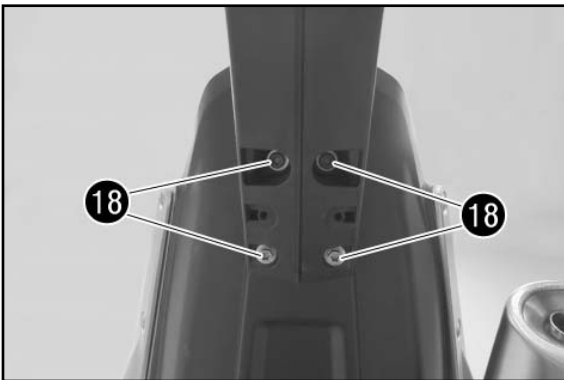

Rear turn signal

Assembly

- Remove screws 18.
- Place license plate holder support on the rear wheel.

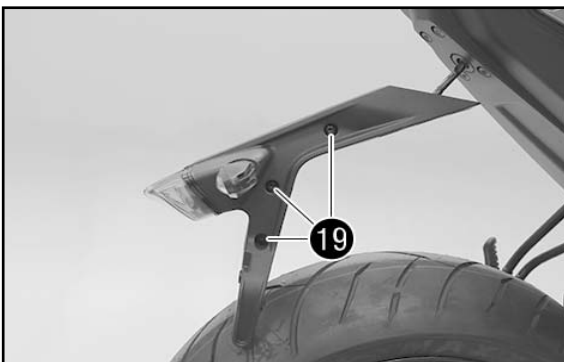

- Remove screws 19.
- Swivel each half of the license plate holder support outwards and detach in area B.
- Place tail light on the rear wheel.

NOTE

The complete license plate holder support can be removed if required. To do so, disconnect the relevant socket connectors under the passenger seat and slip out the cable with rubber grommet.

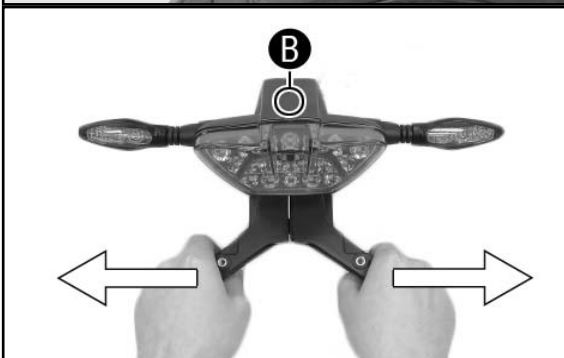

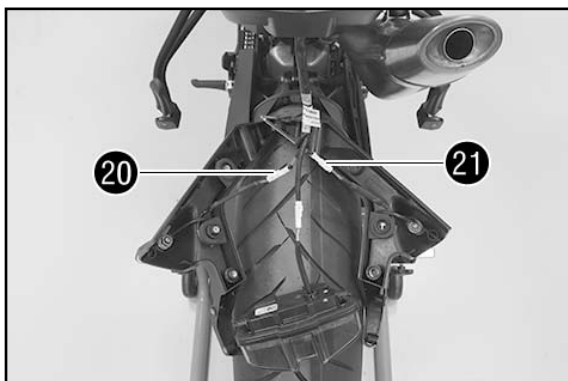

- Disconnect turn signal plug-in connector 20 and 21.
- Take off each half of the license plate holder support.

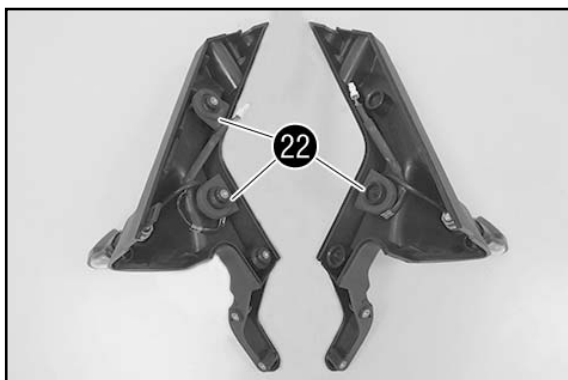

- Remove cable holder 22.

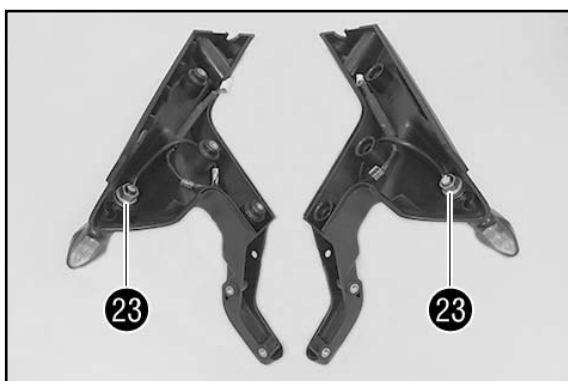

- Remove nuts 23 with the washers.
- Remove the turn signal.

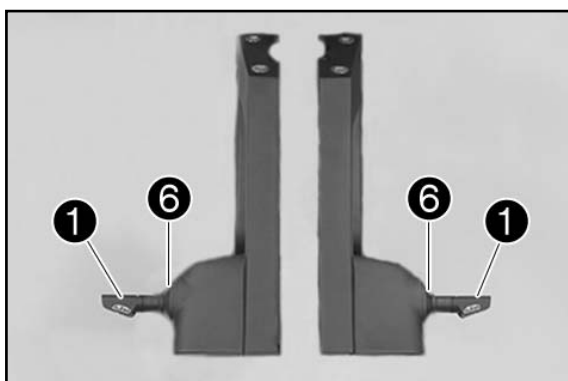

- Preassemble turn signal adapter 6 (included) on turn signal 1 (included).
- Thread in turn signal 1 (included) and position turn signal adapter 6.

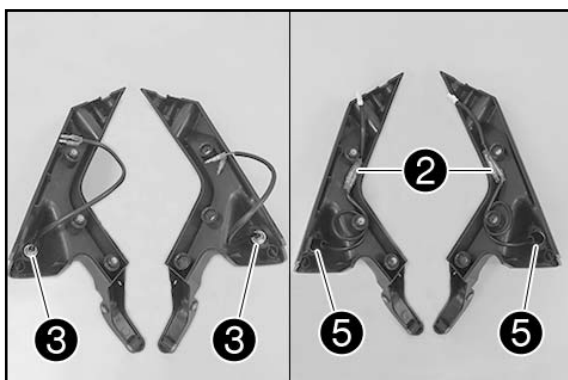

- Mount nuts 3 with washers 4 (all included) and tighten.
- Mount protection caps 5 (included).
- Plug in resistances 2 (included) according to the colors.
- Position the cables.

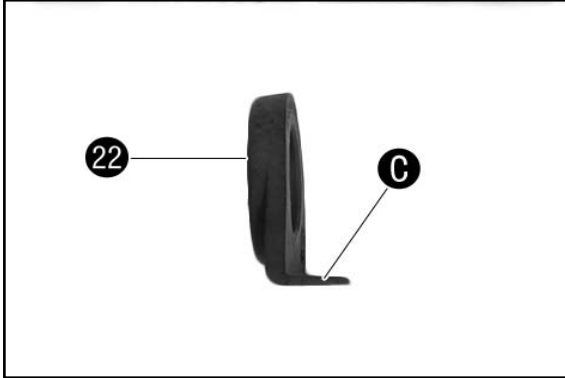
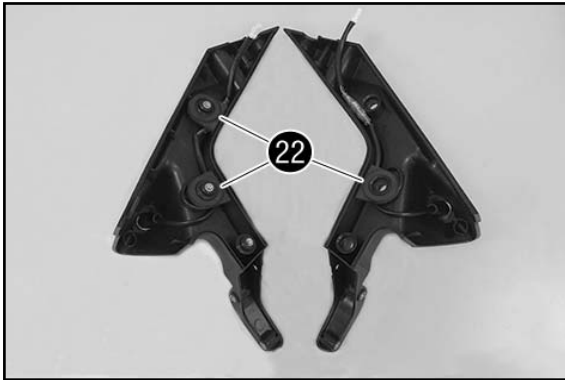

- Mount cable holder 22 with the lip C facing inward.

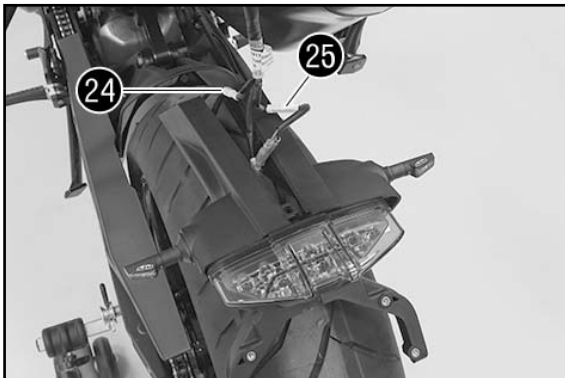

- Disconnect turn signal plug-in connectors 24 and 25.
 - Position each half of the license plate holder support on the tail light.
 - Route the cable without tension.

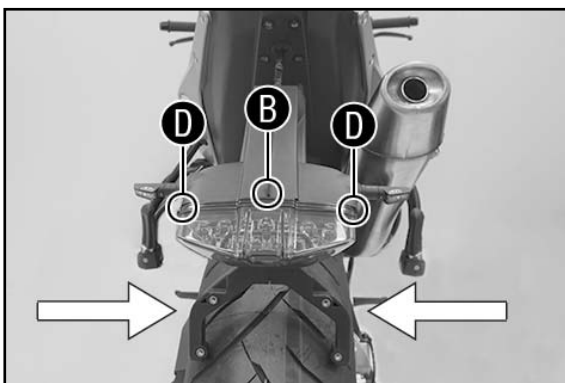

- Latch each half of license plate holder support into place in area B and hook in the tail light in areas D.
 - Join each half of license plate holder support.

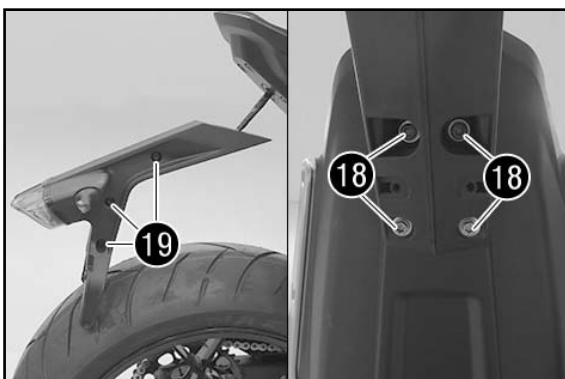

- Mount screws 19 and tighten to 5 Nm.
 - Position the license plate holder support.
 - Mount screws 18 and tighten to 10 Nm (Loctite 243).

Final steps

- Check that the lighting is functioning properly.

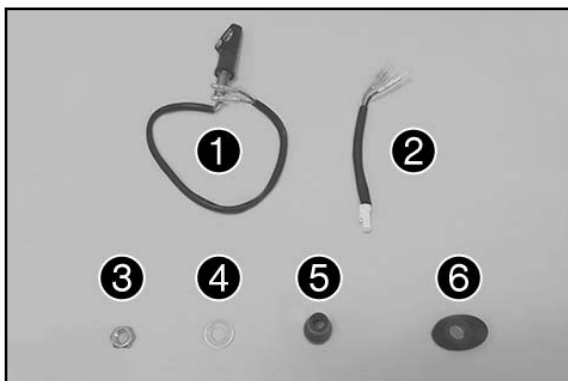

Materiale fornito

- 1 indicatore di direzione ❶
- 1 resistenza ❷
- 1 dado ❸
- 1 rondella ❹
- 1 protezione ❺
- 1 adattatore indicatori di direzione ❻

Indicatore di direzione anteriore

Montaggio

- Disinserire il sistema d'accensione.
- Rimuovere le viti ❷.

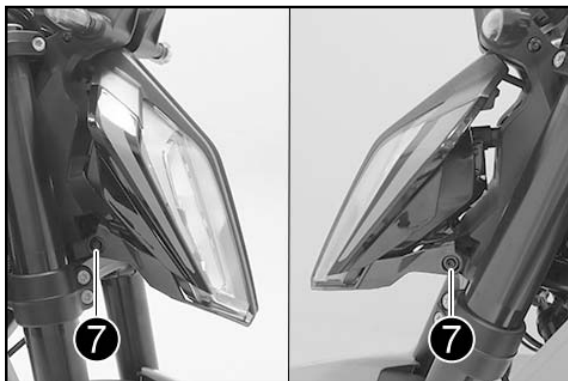

- Svitare completamente la vite di regolazione ❸.

AVVERTENZA

La vite di regolazione è fissata alla mascherina portafaro per mezzo di un supporto a testa sferica. Non estrarre la vite di regolazione dal supporto a testa sferica.

- Ruotare la mascherina portafaro leggermente in avanti e scollegare il connettore ❹.
- Rimuovere il faro.

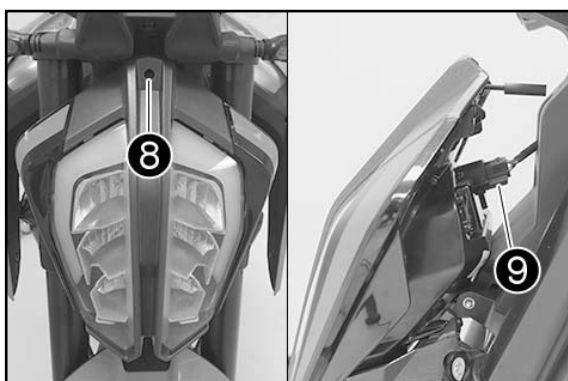

- Rimuovere le viti ❿.
- Rimuovere le viti ⓫.
- Rimuovere le viti ⓬.

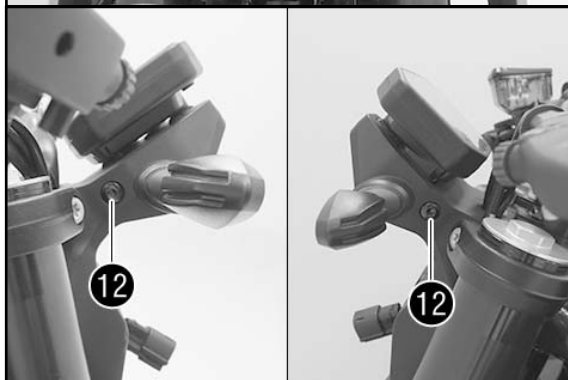
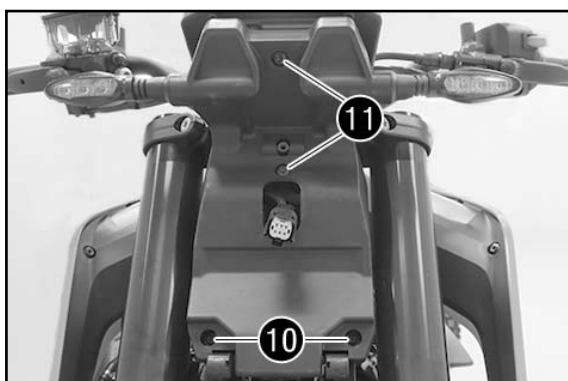

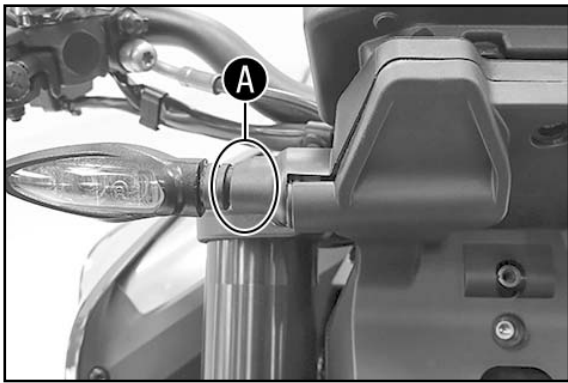

- Afferrare l'indicatore di direzione nella zona **A** e spingerlo con cautela in senso opposto alla direzione di marcia.

✓ La copertura si sgancia come si vede nella figura.

- Ripetere la fase di lavoro sul lato opposto.
- Rimuovere la copertura.

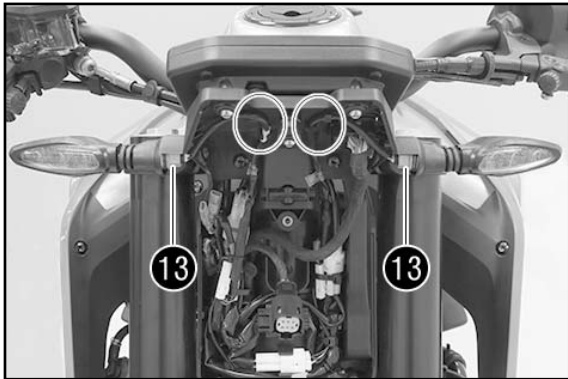

- Svitare completamente i dadi **13** dalla filettatura.
- Rimuovere il cavo dell'indicatore di direzione dai supporti in alto.

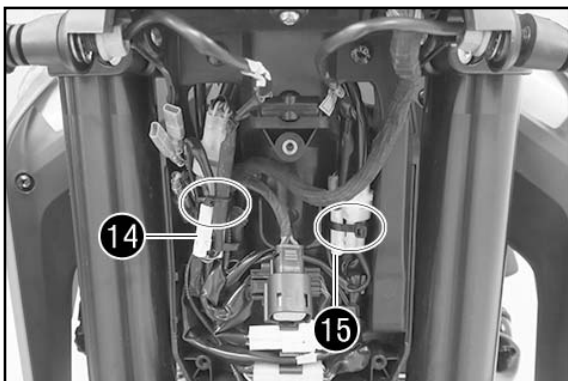

- Rimuovere le fascette serracavi.
- Staccare i connettori degli indicatori di direzione a destra **14** e a sinistra **15**.
- Rimuovere gli indicatori di direzione con i dadi e le rondelle.

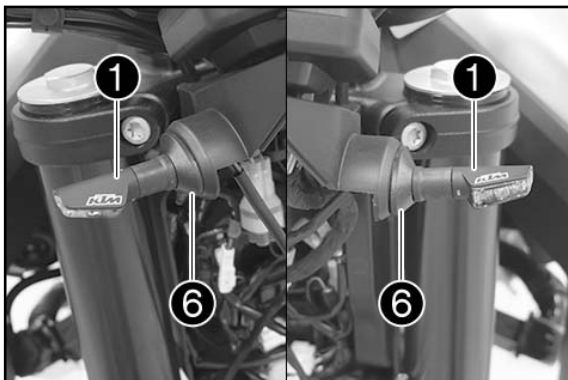

- Premontare l'adattatore indicatori di direzione **6** (in dotazione) sull'indicatore di direzione **1** (in dotazione).
- Infilare l'indicatore di direzione **1** (in dotazione) e posizionarlo con l'adattatore indicatori di direzione **6**.

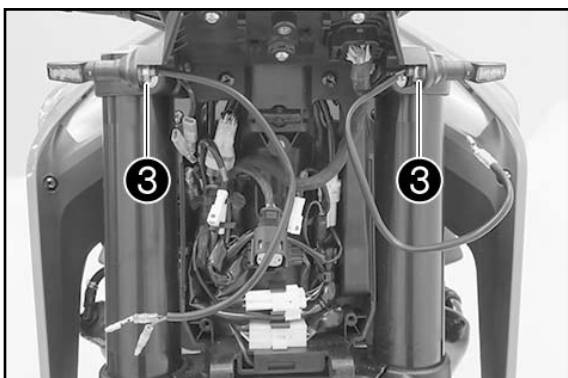

- Montare e serrare i dadi **3** con rondelle **4** (tutto in dotazione).

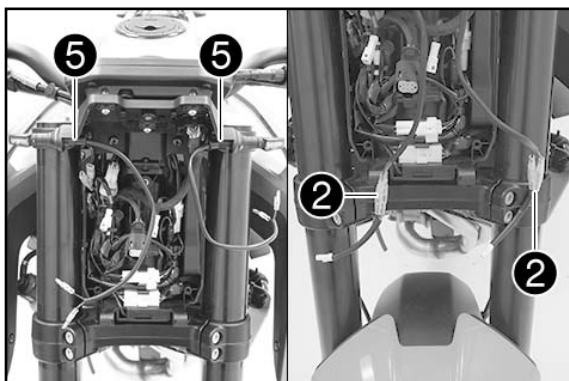

- Montare le protezioni 5 (in dotazione).
- Collegare le resistenze 2 (in dotazione) in base ai colori.

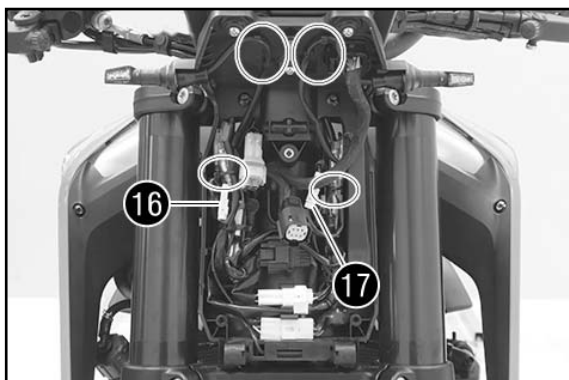

- Collegare i connettori degli indicatori di direzione 16 e 17.
- Montare il cavo dell'indicatore di direzione nei supporti in alto.
- Posare tutti i cavi in modo che non presentino punti in tensione e assicurarli con una fascetta serracavi.

! AVVERTIMENTO

Assicurarsi che il cavo non rischi di venire piegato o bloccato in qualche modo!

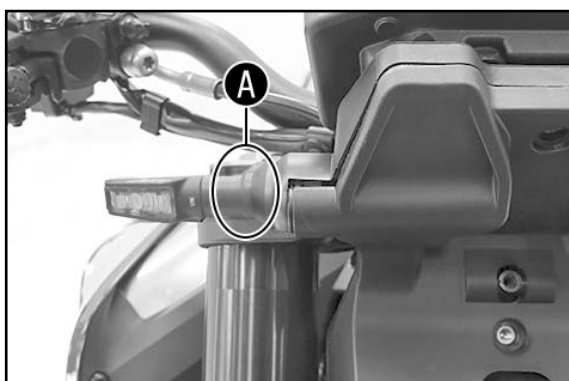

- Posizionare la copertura e far passare il connettore del faro attra verso l'apertura.
- Afferrare l'indicatore di direzione nella zona A e spingerlo con cautela in senso opposto alla direzione di marcia, contemporaneamente premere in sede la copertura.

✓ La copertura si innesta con un clic udibile.

- Ripetere la fase di lavoro sul lato opposto.

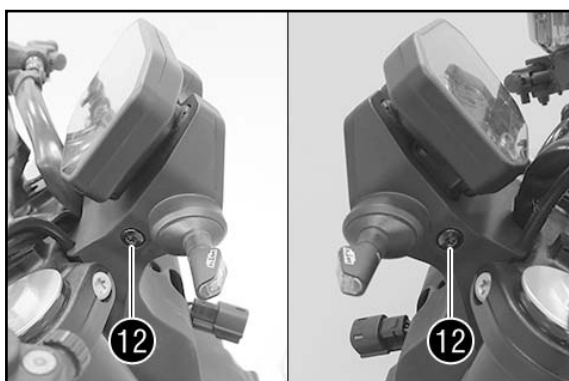

- Montare le viti 12 e serrarle a 5 Nm.
- Montare le viti 11 e serrarle a 5 Nm.
- Montare le viti 10 e serrarle a 2 Nm.

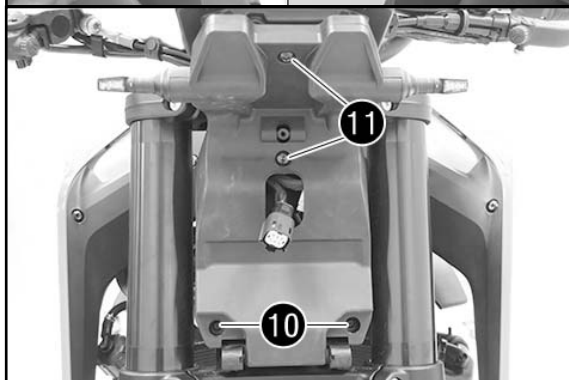

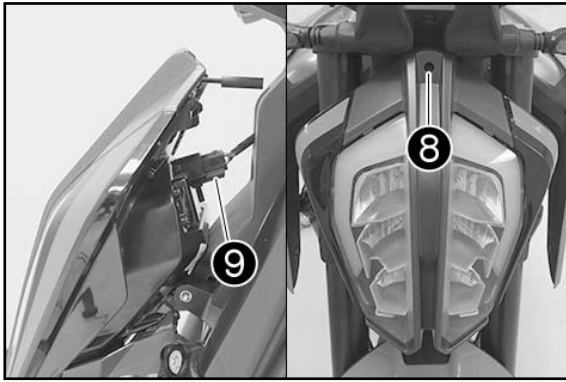

- Collegare il connettore 9.
- Posizionare la mascherina portafaro.
- Montare la vite di regolazione 8.

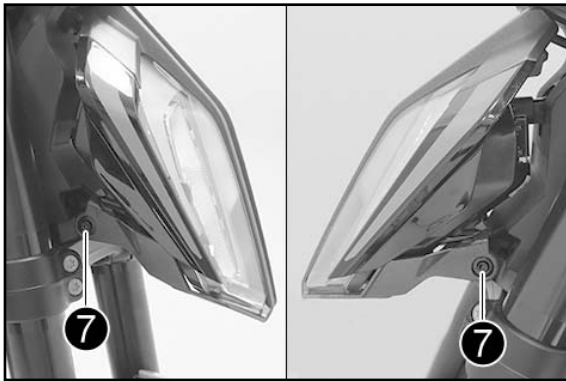

- Montare le viti 7 e serrarle a 2 Nm.

Operazione conclusiva

- Controllare l'orientamento del faro (v. manuale d'uso).
- Regolare la profondità del fascio luminoso del faro (v. manuale d'uso).
- Controllare il funzionamento dell'illuminazione.

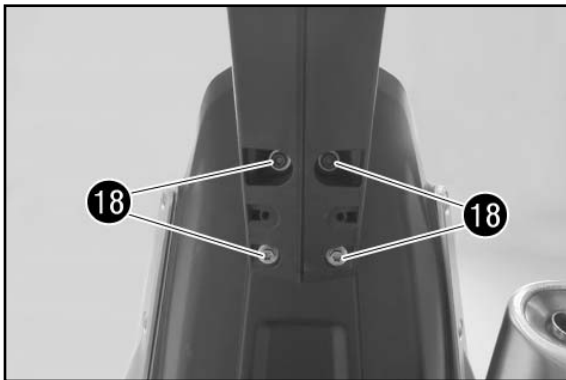

Indicatori di direzione posteriori

Montaggio

- Rimuovere le viti 18.
- Appoggiare il portatarga sulla ruota posteriore.

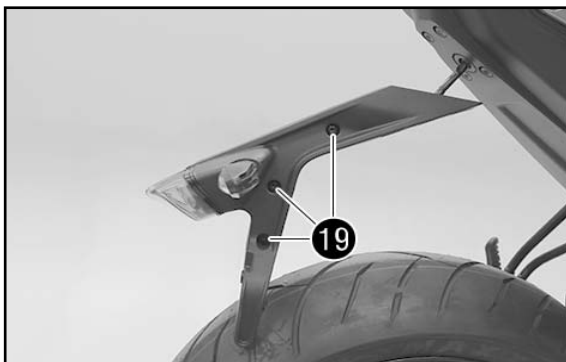

- Rimuovere le viti 19.
- Ruotare verso l'esterno le due metà del portatarga e disimpegnarle nella zona B.
- Appoggiare la luce di posizione posteriore sulla ruota posteriore.

AVVERTENZA

In base alle necessità è possibile rimuovere l'intero portatarga. A tale scopo scollegare il rispettivo connettore sotto la sella del passeggero e sfilare il cavo con il passacavo in gomma.

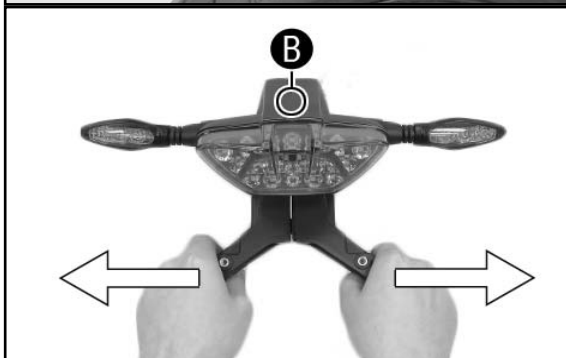

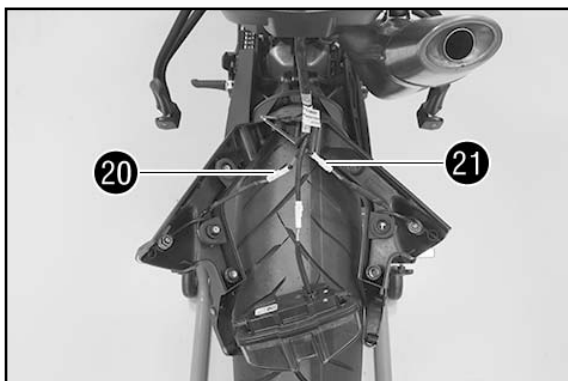

- Scollegare il connettore dell'indicatore di direzione ❷❶ e ❷❶.
- Rimuovere le due metà del portatarga.

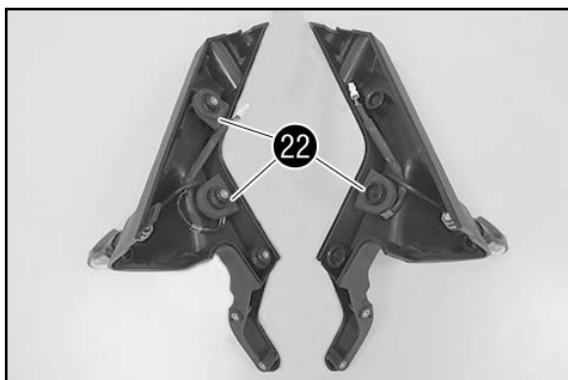

- Rimuovere il portacavo ❷❷.

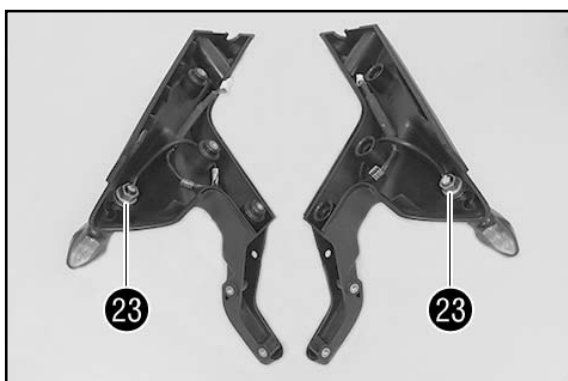

- Rimuovere i dadi ❷❸ con le rondelle.
- Rimuovere l'indicatore di direzione.

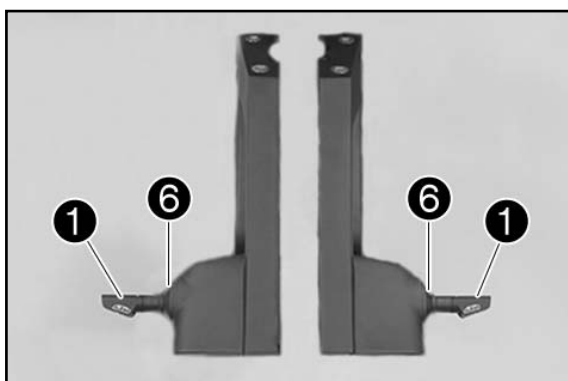

- Premontare l'adattatore indicatori di direzione ❷❹ (in dotazione) sull'indicatore di direzione ❷❶ (in dotazione).
- Infilare l'indicatore di direzione ❷❶ (in dotazione) e posizionarlo con l'adattatore indicatori di direzione ❷❹.

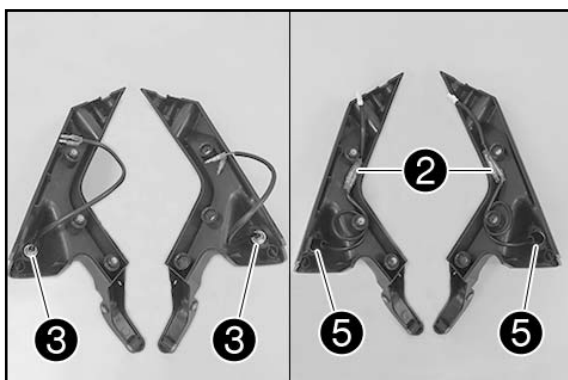

- Montare e serrare i dadi ❷❹ con rondelle ❷❺ (tutto in dotazione).
- Montare le protezioni ❷❻ (in dotazione).
- Collegare le resistenze ❷❼ (in dotazione) in base ai colori.
- Posizionare il cavo.

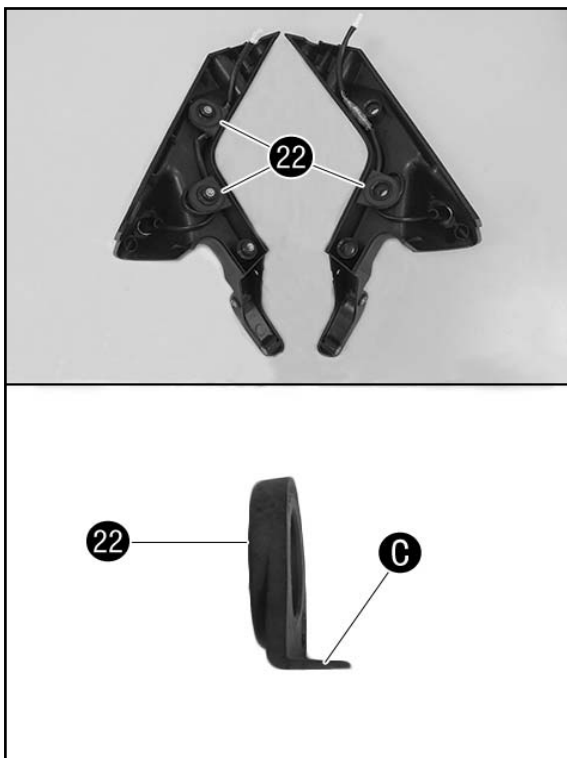

- Montare il portacavo 22 con il labbro C rivolto all'interno.

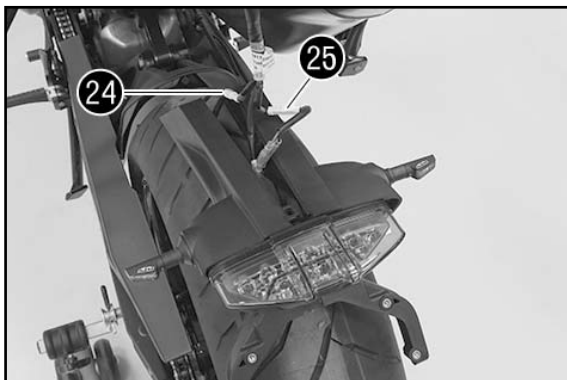

- Collegare il connettore dell'indicatore di direzione 24 e 25.
 - Posizionare le due metà del portatarga sulla luce di posizione posteriore.
 - Posizionare il cavo prestando attenzione a non metterlo in tensione.

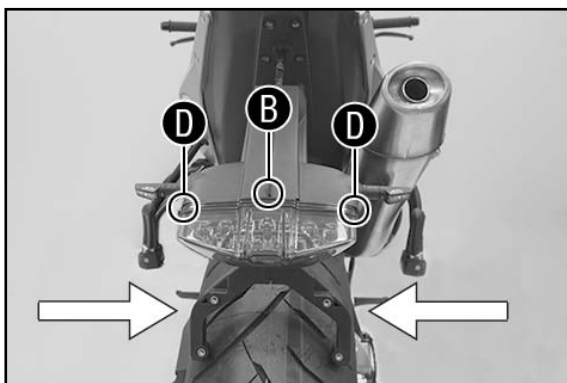

- Innestare le due metà del portatarga nella zona B e agganciare la luce di posizione posteriore nelle zone D.
 - Ricollegare le due metà del portatarga.

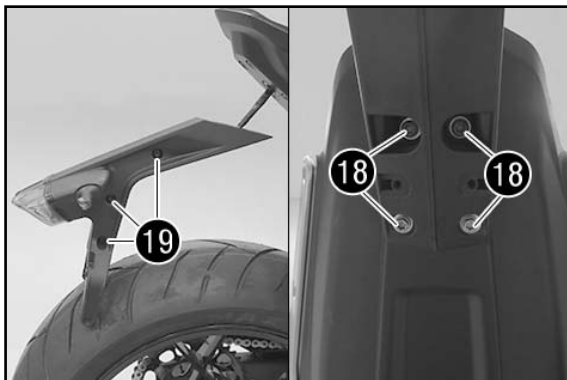

- Montare le viti 19 e serrarle a 5 Nm.
 - Posizionare il portatarga.
 - Montare le viti 18 e serrarle a 10 Nm (Loctite 243).

Operazione conclusiva

- Controllare il funzionamento dell'illuminazione.

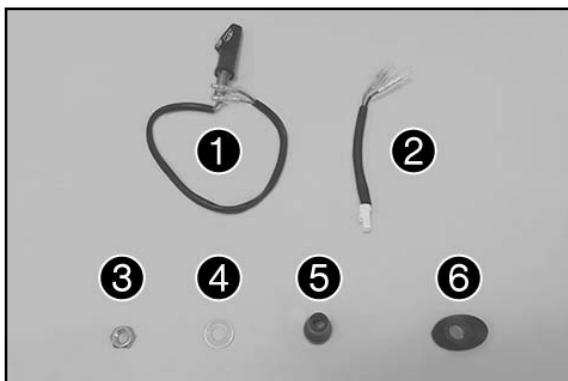

Contenu de la livraison

- 1x clignotant ❶
- 1x résistance ❷
- 1x écrou ❸
- 1x rondelle ❹
- 1x capuchon ❺
- 1x adaptateur de clignotant ❻

Clignotant avant

Montage

- Couper le contact.
- Retirer les vis ❷.

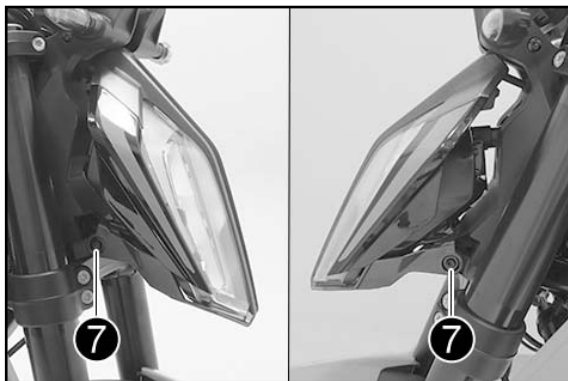

- Dévisser complètement la vis de réglage ❸.

REMARQUE

La vis de réglage est maintenue sur la plaque-phare par une fixation à tête de rotule.
Ne pas retirer la vis de réglage de la fixation à tête de rotule.

- Basculer la plaque-phare légèrement vers l'avant et débrancher le connecteur ❹.
- Déposer le phare.

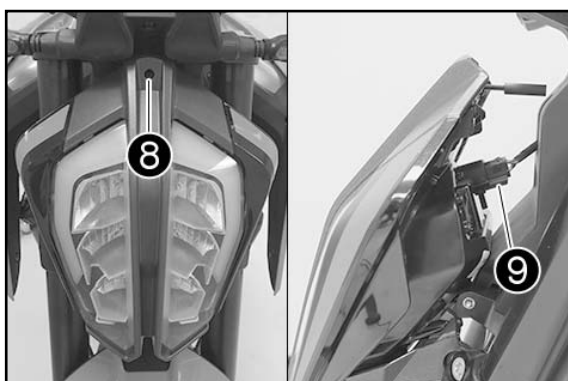

- Retirer les vis ❿.
- Retirer les vis ⓫.
- Retirer les vis ⓬.

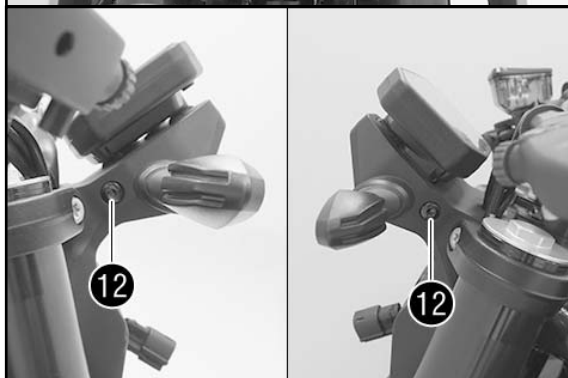
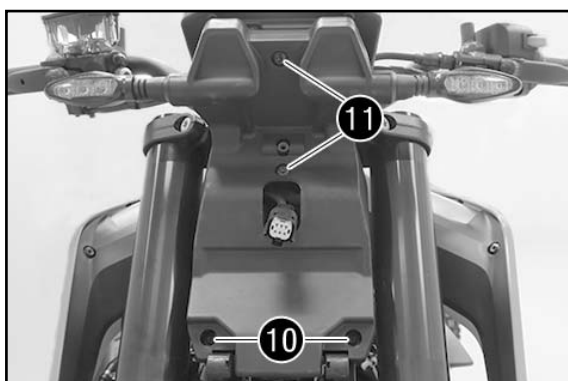

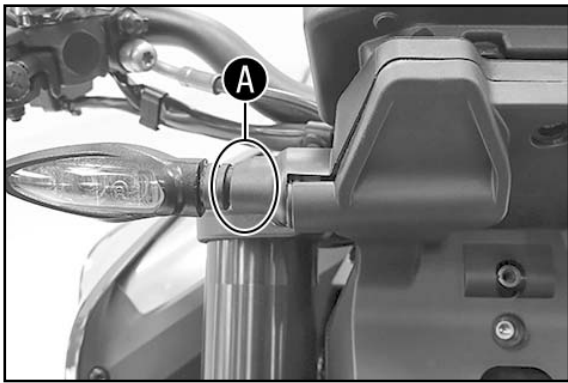

- Saisir le clignotant dans la zone **A** et appuyer avec précaution dans la direction opposée au sens de marche.

✓ Le cache se détache comme indiqué sur la figure.

- Répéter l'étape de travail du côté opposé.
- Déposer le cache.

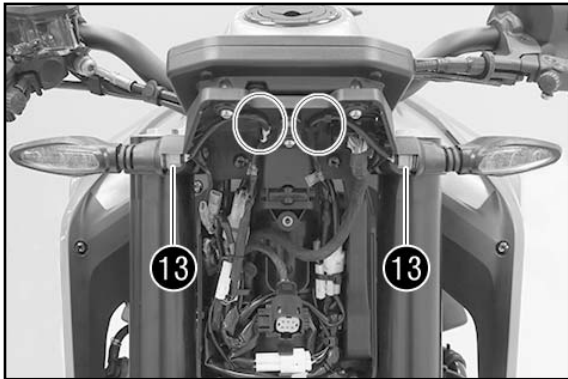

- Desserrer complètement les écrous **13** du filetage.
- Retirer le câble du clignotant des supports supérieurs.

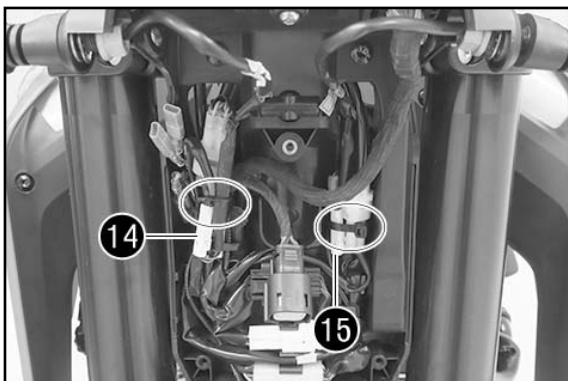

- Retirer le rilsan.
- Débrancher les connecteurs du clignotant droit **14** et gauche **15**.
- Retirer le clignotant ainsi que les écrous et les disques.

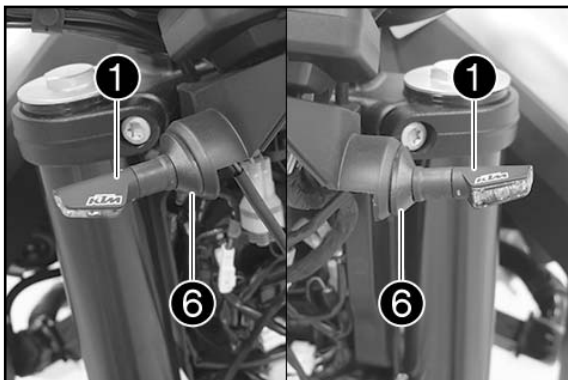

- Prémonter l'adaptateur de clignotant **6** (contenu de la livraison) sur le clignotant **1** (contenu de la livraison).
- Enfiler le clignotant **1** (contenu de la livraison) et le positionner avec l'adaptateur de clignotant **6**.

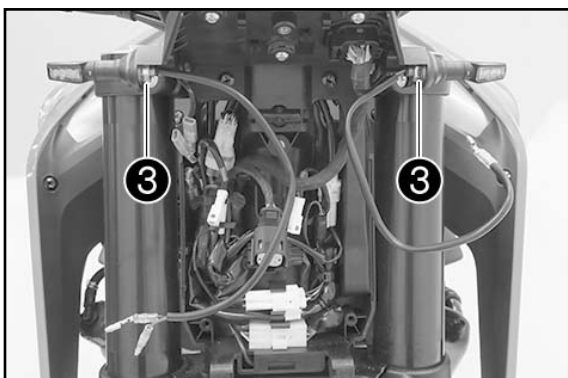

- Mettre en place les écrous **3** avec les rondelles **4** (tous compris dans la livraison) et les serrer.

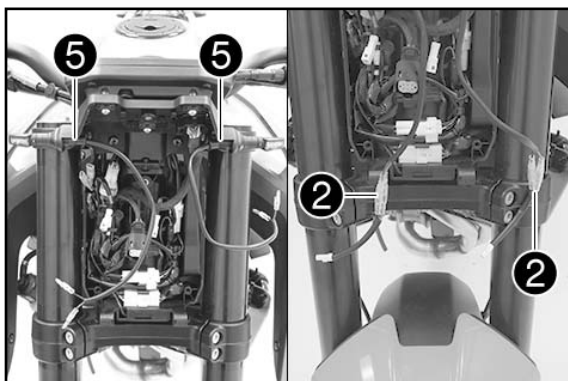

- Mettre en place les capuchons 5 (contenu de la livraison).
- Brancher les résistances 2 (contenu de la livraison) en respectant les couleurs.

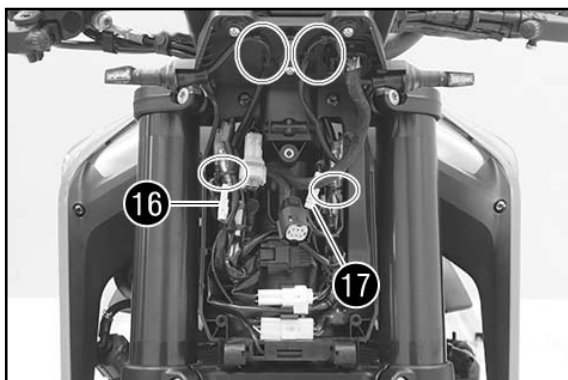

- Brancher les connecteurs du clignotant 16 et 17.
- Mettre en place le câble du clignotant dans les supports supérieurs.
- Poser tous les câbles de manière à ce qu'ils ne soient soumis à aucune contrainte et les bloquer à l'aide d'un serre-câbles.

! ATTENTION

Veiller à ce que le câble ne soit ni plié ni coincé !

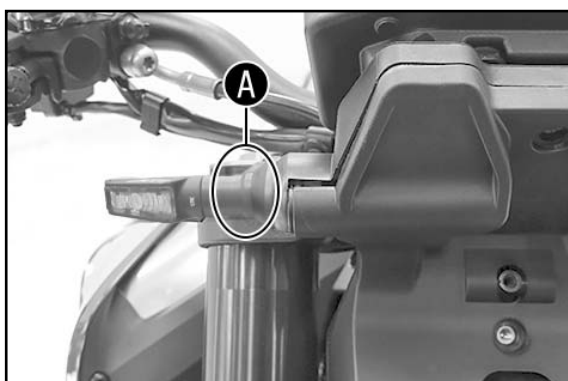

- Positionner le cache en faisant passer le connecteur du phare par l'ouverture.
- Saisir le clignotant dans la zone A et appuyer avec précaution dans la direction opposée au sens de marche tout en appuyant fermement sur le cache.

✓ L'emboîtement du cache est perceptible à l'oreille.

- Répéter l'étape de travail du côté opposé.

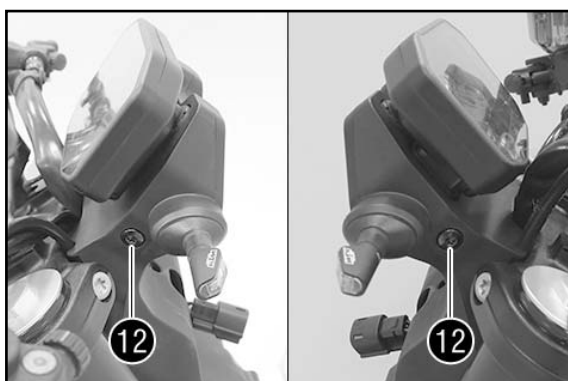

- Mettre en place les vis 12 et les serrer à 5 Nm.
- Mettre en place les vis 11 et les serrer à 5 Nm.
- Mettre en place les vis 10 et les serrer à 2 Nm.

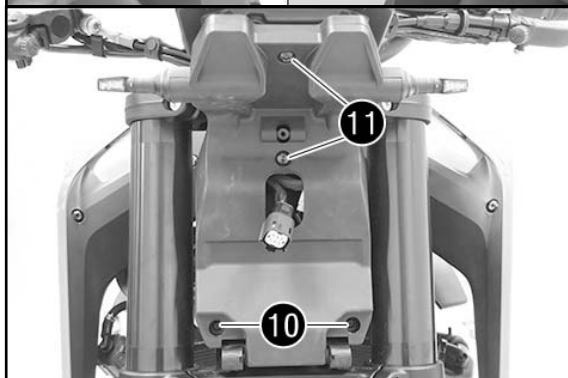

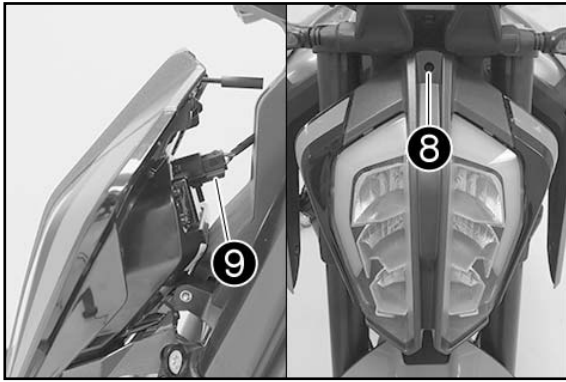

- Brancher le connecteur ⑨.
- Positionner la plaque-phare.
- Mettre en place la vis de réglage ⑧.

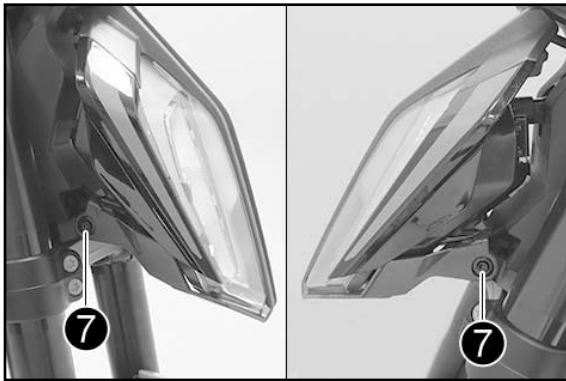

- Mettre les vis ⑦ en place et les serrer à 2 Nm.

Travaux ultérieurs

- Contrôler le réglage du phare (voir le manuel d'utilisation).
- Régler la portée du phare (voir le manuel d'utilisation).
- Contrôler le fonctionnement de l'éclairage.

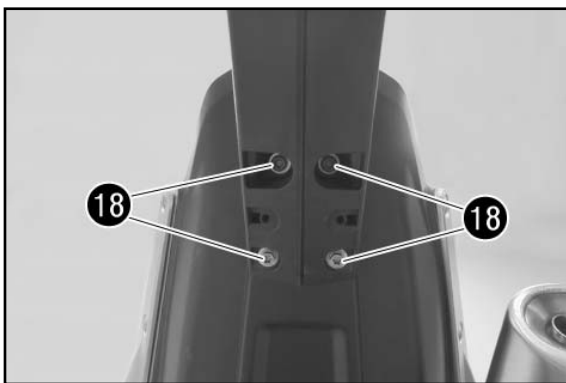

Clignotant arrière

Montage

- Retirer les vis ⑱.
- Déposer le support de plaque d'immatriculation sur la roue arrière.

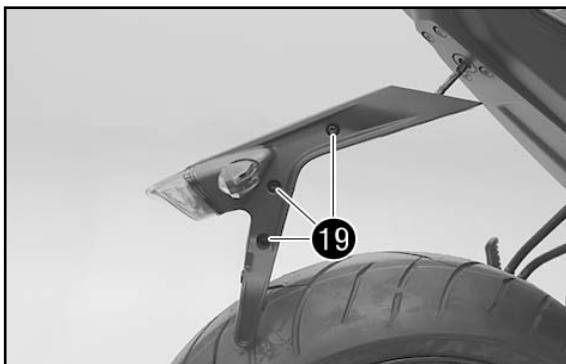

- Retirer les vis ⑱.
- Pivoter les demi porte-plaque vers l'extérieur et les décrocher au niveau de l'emplacement ⑱.
- Déposer le feu arrière sur la roue arrière.

REMARQUE

Au besoin, il est possible de retirer le support de plaque d'immatriculation complet. Pour cela, débrancher le connecteur correspondant situé sous la selle passager et dégager le câble avec la gaine en caoutchouc.

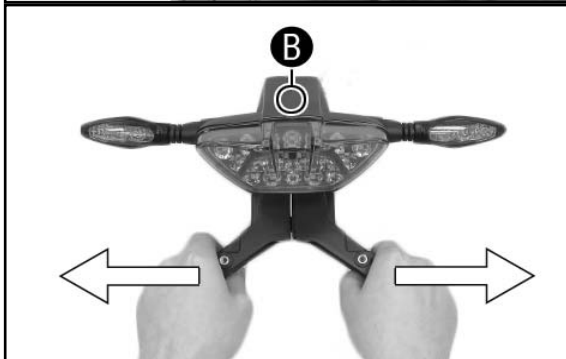

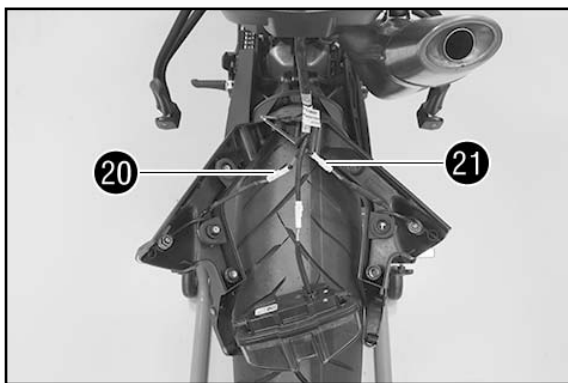

- Débrancher les connecteurs 20 et 21 du clignotant.
- Déposer les demi porte-plaque.

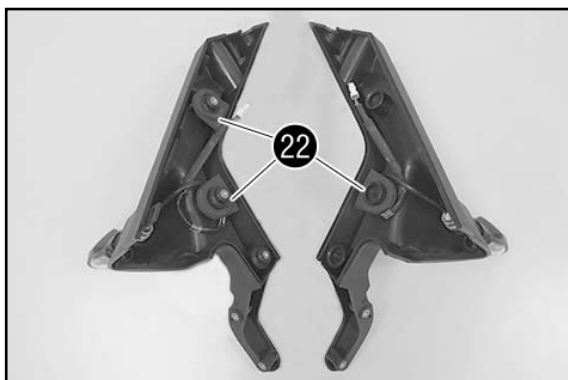

- Retirer le support de câble 22.

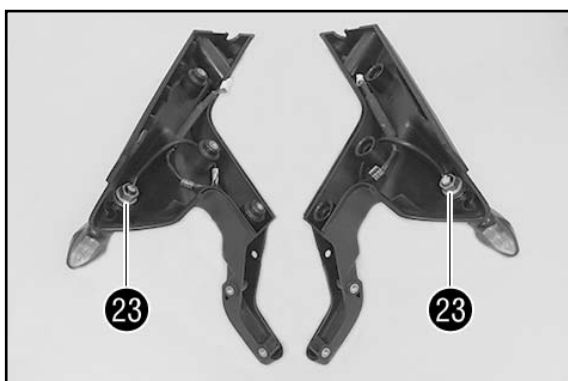

- Retirer les écrous 23 avec les rondelles.
- Retirer le clignotant.

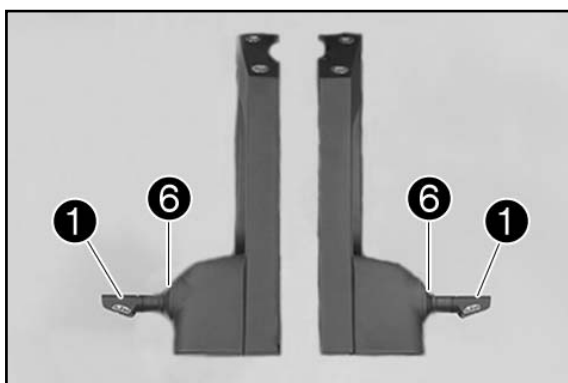

- Prémonter l'adaptateur de clignotant 6 (contenu de la livraison) sur le clignotant 1 (contenu de la livraison).
- Enfiler le clignotant 1 (contenu de la livraison) et le positionner avec l'adaptateur de clignotant 6.

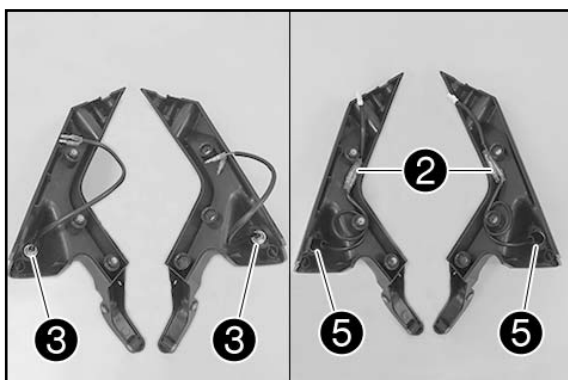

- Mettre en place les écrous 3 avec les rondelles 4 (tous compris dans la livraison) et les serrer.
- Mettre en place les capuchons 5 (contenu de la livraison).
- Brancher les résistances 2 (contenu de la livraison) en respectant les couleurs.
- Positionner le câble.

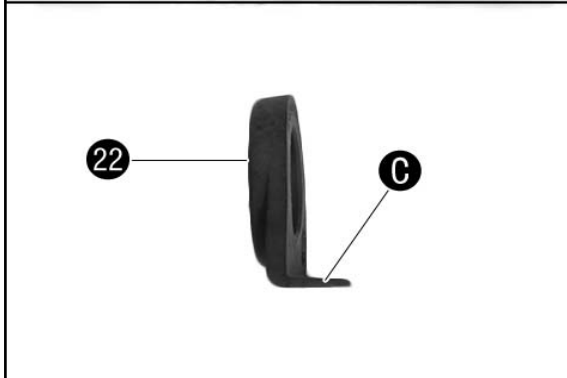
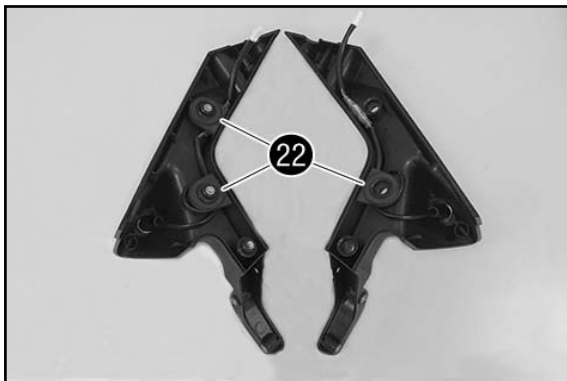

- Monter le support de câble 22 avec la lèvre C vers l'intérieur.

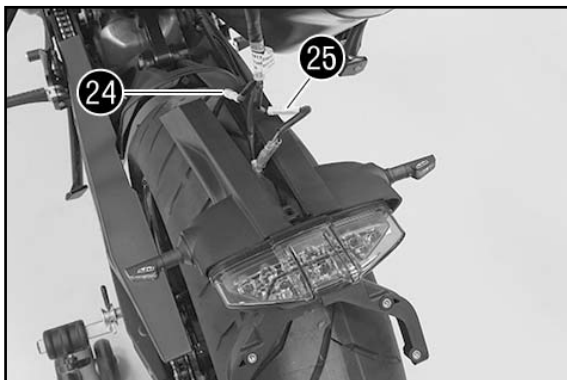

- Brancher les connecteurs 24 et 25 du clignotant.
 - Positionner les demi porte-plaque sur le feu arrière.
 - Poser le câble de manière à ce qu'il ne soit soumis à aucune contrainte.

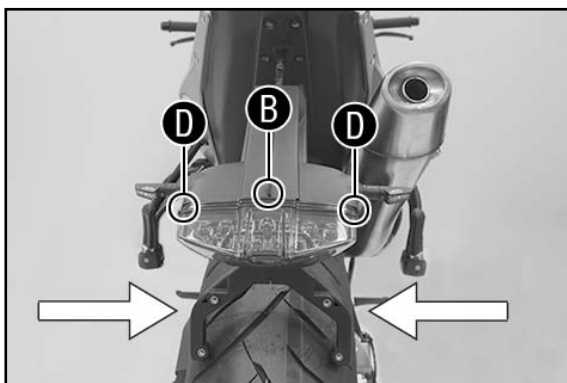

- Enclencher les demi porte-plaque dans la zone B et accrocher le feu arrière dans les zones D.
 - Brancher les demi porte-plaque.

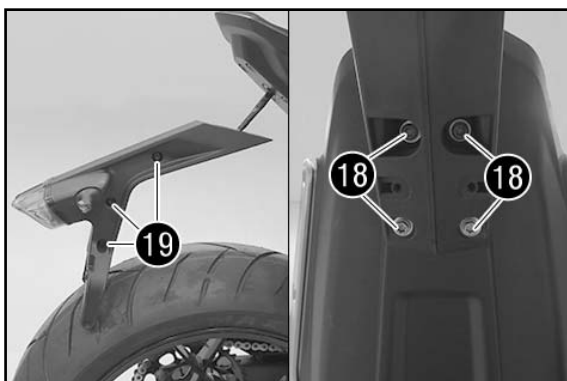

- Mettre en place les vis 19 et les serrer à 5 Nm.
 - Mettre en place la support de plaque d'immatriculation.
 - Mettre en place les vis 18 et les serrer à 10 Nm (Loctite 243).

Travaux ultérieurs

- Contrôler le fonctionnement de l'éclairage.

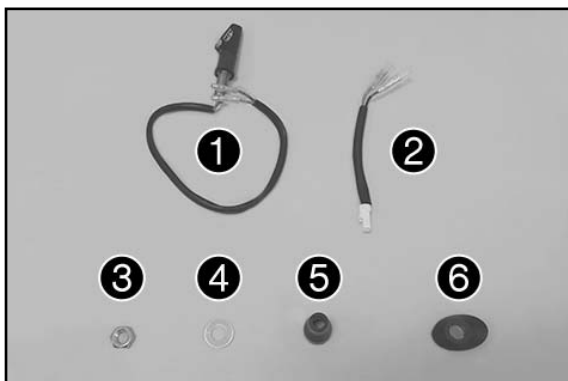

Volumen de suministro

- 1x intermitente ❶
- 1x resistencia ❷
- 1x tuerca ❸
- 1x arandela ❹
- 1x cubierta de protección ❺
- 1x adaptador de intermitente ❻

Intermitente delantero

Montaje

- Desconectar el sistema de encendido.
- Retirar los tornillos ❷.

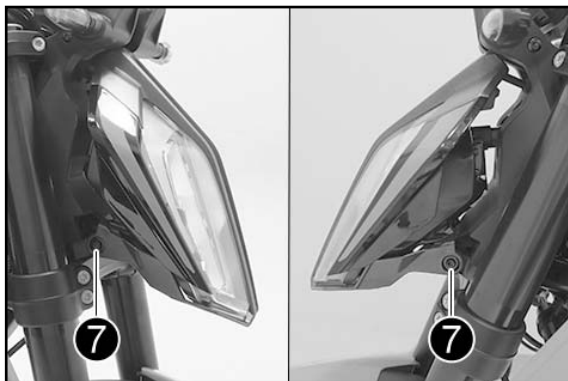

- Extraer completamente el mando de ajuste ❸.

AVISO

El mando de ajuste está sujeto mediante un soporte de rótula a la máscara de faro.
No sacar el mando de ajuste del soporte de rótula.

- Abatir la máscara de faro ligeramente hacia delante y desconectar la clema ❹.
- Quitar el faro.

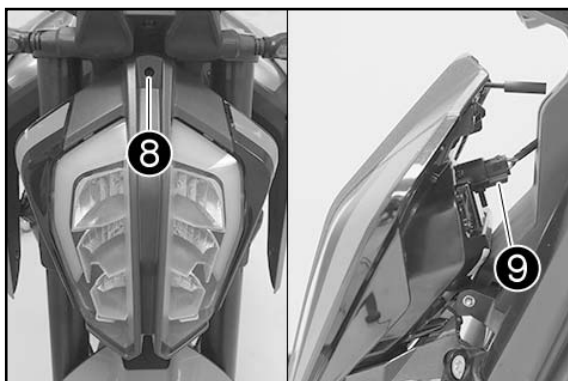

- Retirar los tornillos ❿.
- Retirar los tornillos ⓫.
- Retirar los tornillos ⓬.

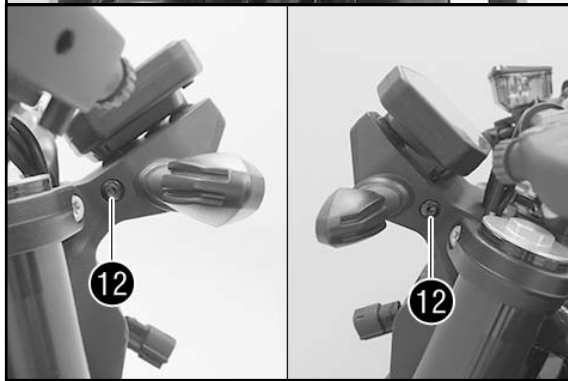
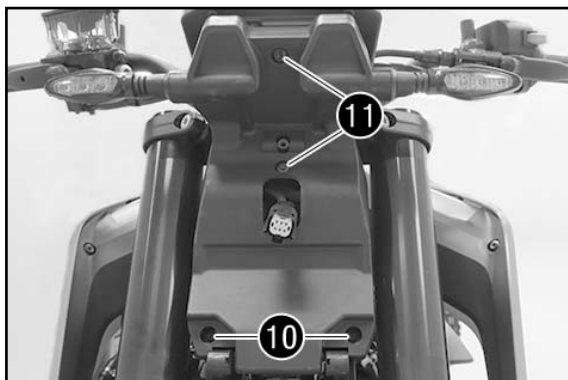

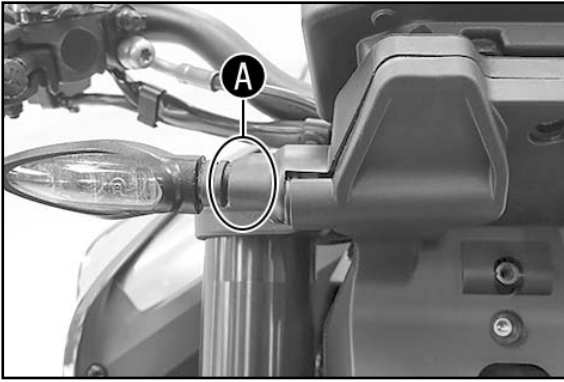

- Sujetar el intermitente en la zona **A** y empujarlo con cuidado en contra de la dirección de marcha.

✓ La tapa se suelta como se muestra en la imagen.

- Repetir el paso de trabajo en el lado opuesto.
- Retirar la tapa.

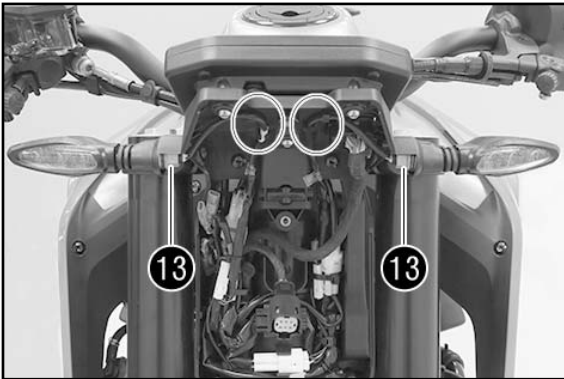

- Soltar completamente las tuercas **13** de la rosca.
- Retirar el cable del intermitente de las fijaciones de arriba.

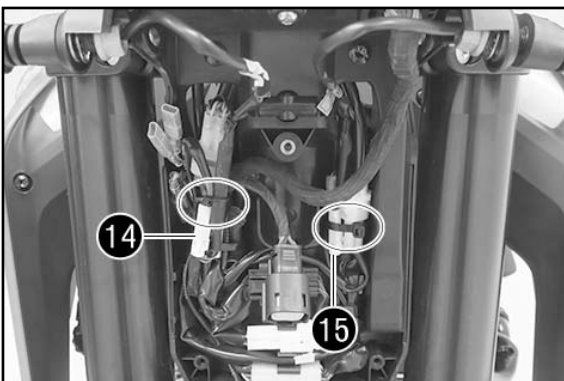

- Retirar las bridas.
- Desconectar los conectores del intermitente a la derecha **14** e izquierda **15**.
- Retirar el intermitente con las tuercas y arandelas.

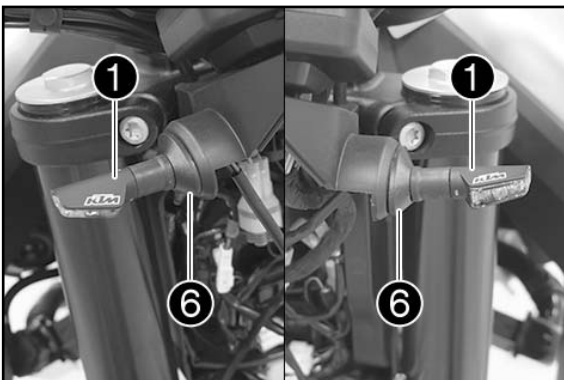

- Premontar el adaptador del intermitente **6** (volumen de suministro) en el intermitente **1** (volumen de suministro).
- Insertar el intermitente **1** (volumen de suministro) y colocarlo con el adaptador del intermitente **6**.

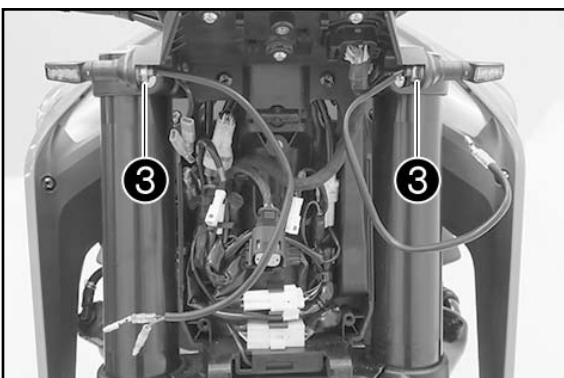

- Montar y apretar las tuercas **3** con las arandelas **4** (todo incluido en el volumen de suministro).

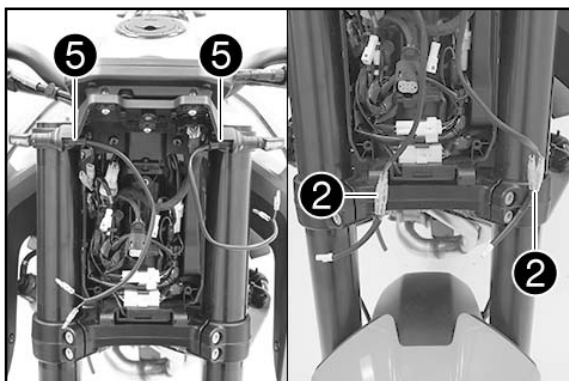

- Montar las cubiertas de protección ⑤ (volumen de suministro).
- Insertar las resistencias ② (volumen de suministro) según sus colores.

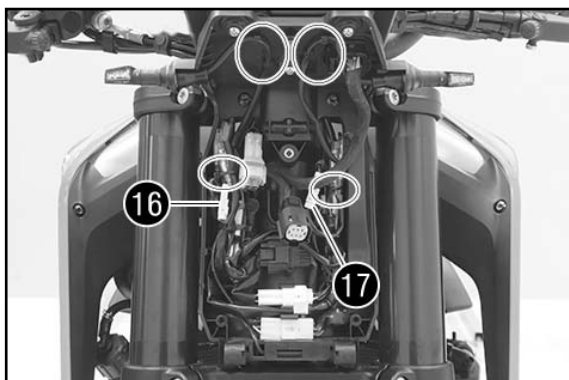

- Enchufar los conectores del intermitente ⑯ y ⑰.
- Montar el cable del intermitente en las fijaciones de arriba.
- Tender todos los cables sin tensiones y asegurarlos con bridas.

! AVISO

¡Asegurarse de que el cable no pueda retorcerse ni quedar apriionado!

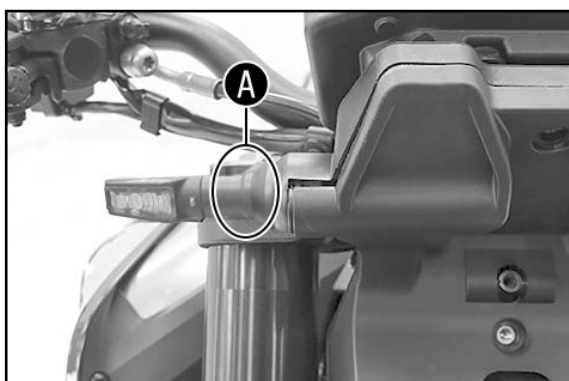

- Colocar la tapa pasando el conector del faro por la abertura.
- Sujetar el intermitente en la zona A y empujarlo con cuidado en contra de la dirección de marcha, a la vez que se aprieta la tapa.

✓ La tapa se enclava de manera audible.

- Repetir el paso de trabajo en el lado opuesto.

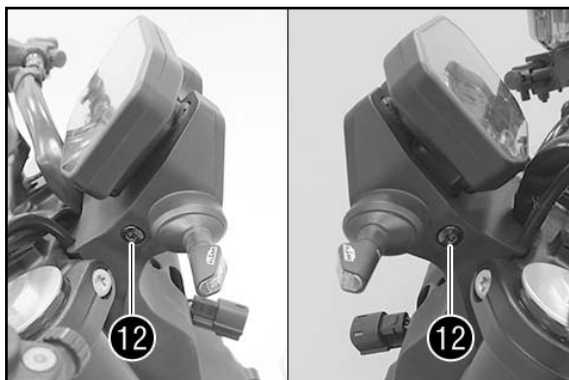

- Montar los tornillos ⑫ y apretarlos a 5 Nm.
- Montar los tornillos ⑪ y apretarlos a 5 Nm.
- Montar los tornillos ⑩ y apretarlos a 2 Nm.

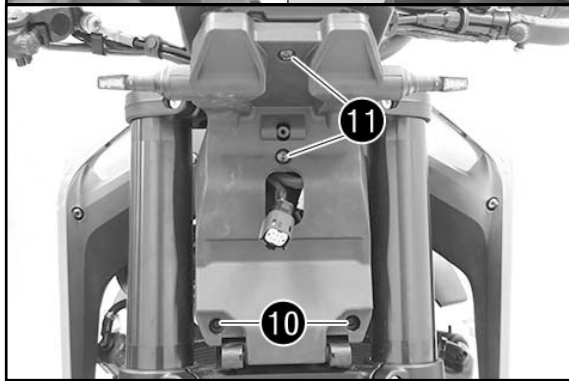

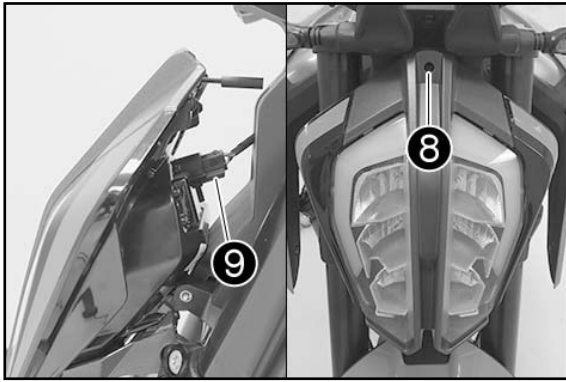

- Enchufar la clema 9.
- Colocar la máscara de faro.
- Montar el mando de ajuste 8.

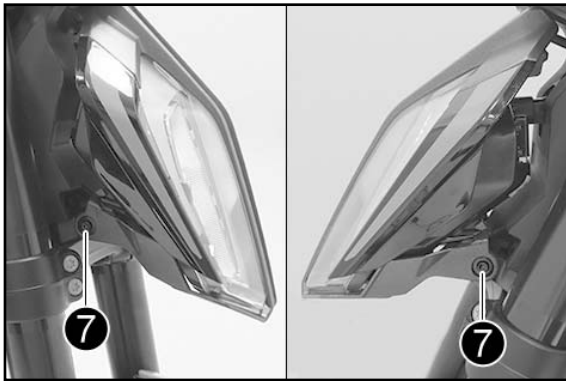

- Montar los tornillos 7 y apretarlos a 2 Nm.

Trabajos posteriores

- Comprobar el ajuste del faro (véase el manual de instrucciones).
- Ajustar la distancia de alumbrado del faro (véase el manual de instrucciones).
- Comprobar el funcionamiento del alumbrado.

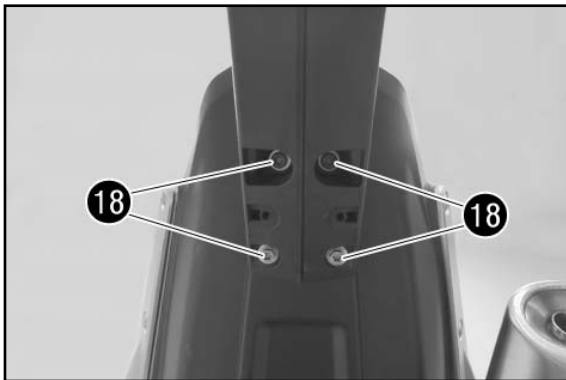

Intermitentes traseros

Montaje

- Retirar los tornillos 18.
- Depositar el soporte de matrícula en la rueda trasera.

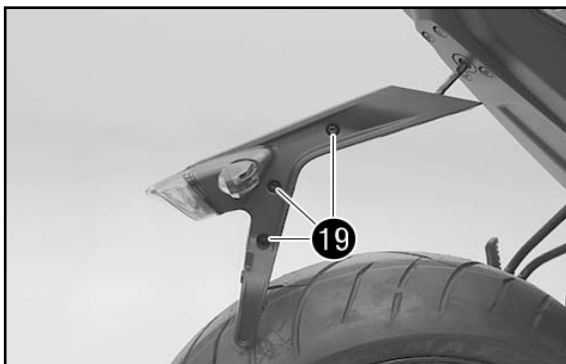

- Retirar los tornillos 19.
- Girar hacia fuera las mitades del soporte de la placa de matrícula y desengancharlas por la zona B.
- Depositar el piloto trasero en la rueda trasera.

AVISO

Si es necesario, se puede retirar el soporte de matrícula completo. Para ello, desconectar la clema correspondiente del asiento del pasajero y extraer el cable con el pasahilos de caucho.

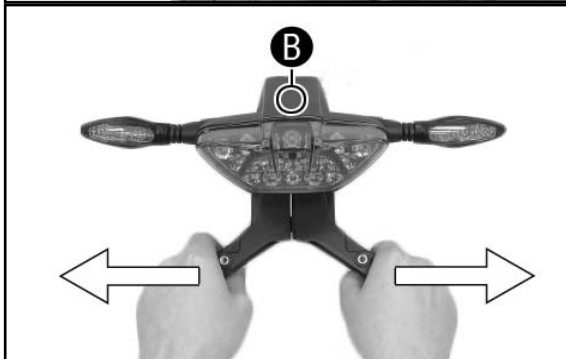

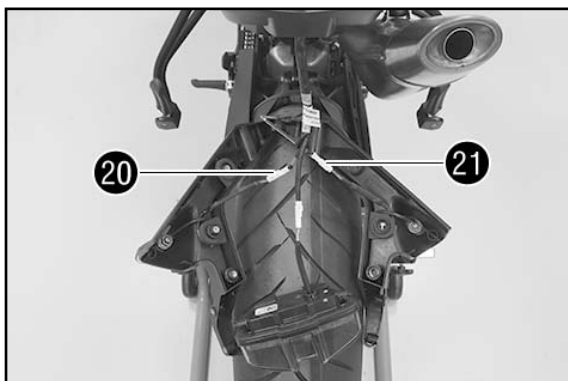

- Desconectar los conectores del intermitente 20 y 21.
- Quitar las mitades del soporte de matrícula.

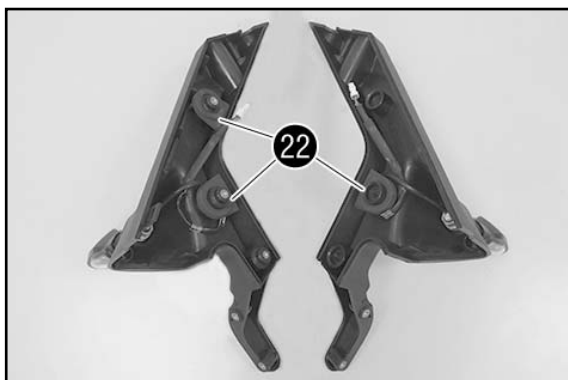

- Retirar los portacables 22.

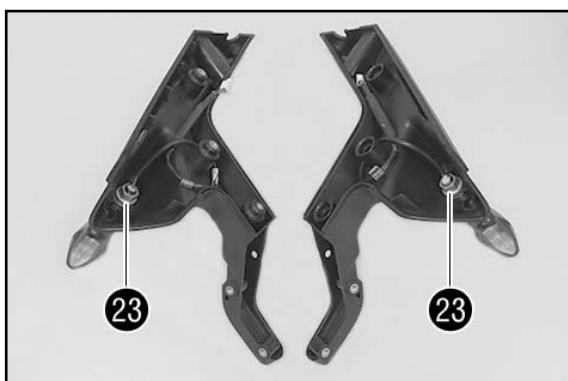

- Retirar las tuercas 23 con las arandelas.
- Retirar el intermitente.

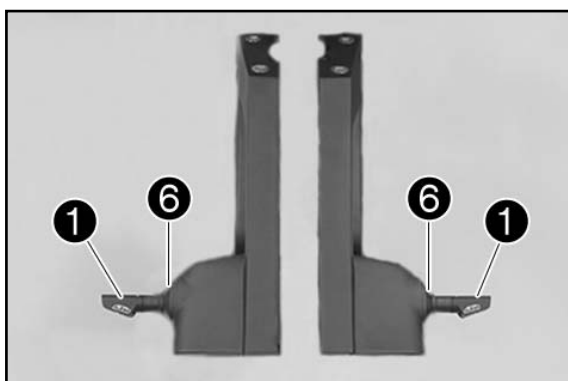

- Premontar el adaptador del intermitente 6 (volumen de suministro) en el intermitente 1 (volumen de suministro).
- Insertar el intermitente 1 (volumen de suministro) y colocarlo con el adaptador del intermitente 6.

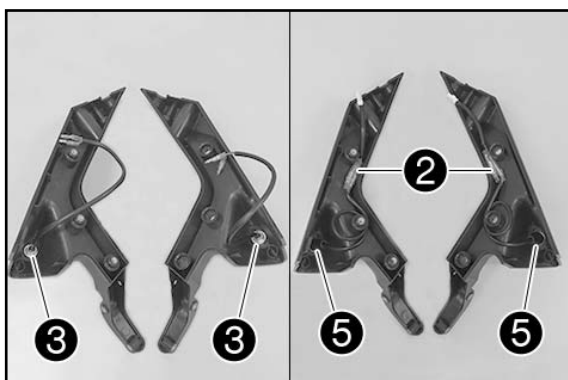

- Montar y apretar las tuercas 3 con las arandelas 4 (todo incluido en el volumen de suministro).
- Montar las cubiertas de protección 5 (volumen de suministro).
- Insertar las resistencias 2 (volumen de suministro) según sus colores.
- Posicionar el cable.

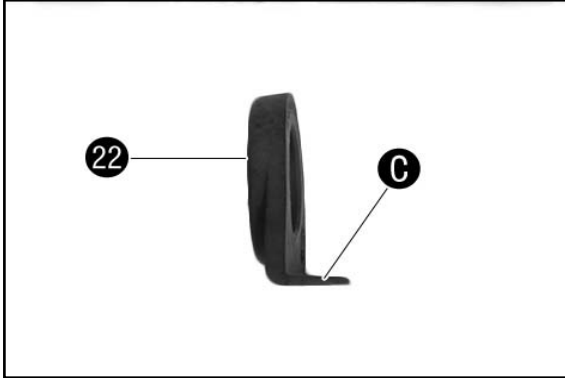
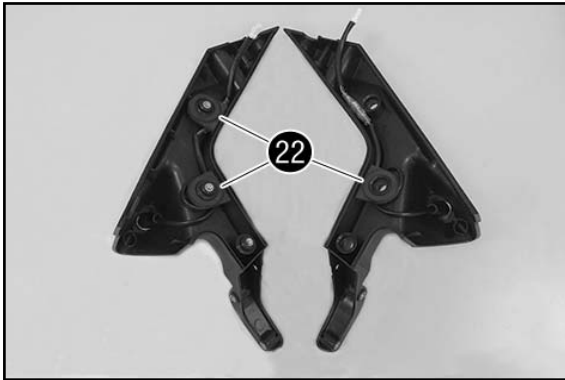

- Montar los portacables 22 con el labio C hacia dentro.

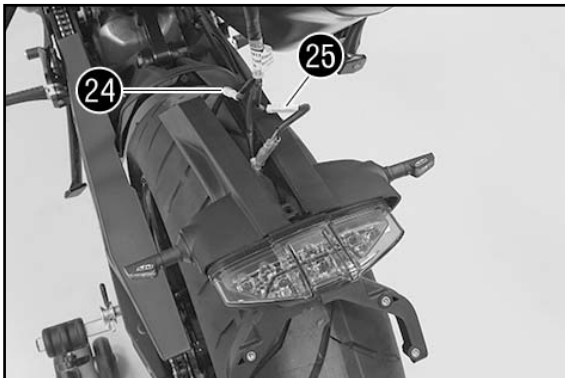

- Enchufar los conectores del intermitente 24 y 25.
- Posicionar las mitades del soporte de matrícula en el piloto trasero.
- Tender los cables sin tensiones.

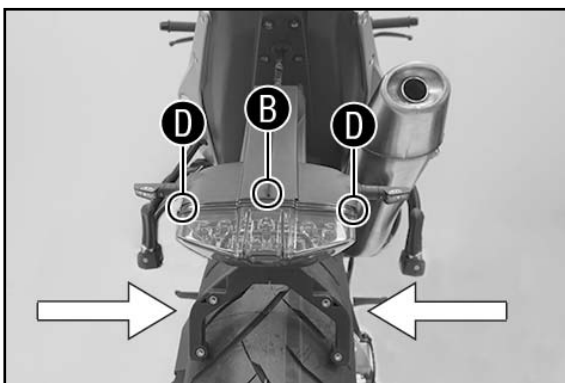

- Encajar las mitades del soporte de la placa de matrícula en la zona B y enganchar el piloto trasero en las zonas D.
- Ensamblar las mitades del soporte de matrícula.

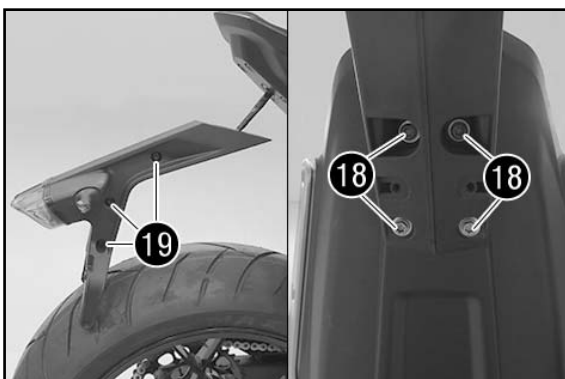

- Montar los tornillos 19 y apretarlos a 5 Nm.
- Posicionar el soporte de la placa de matrícula.
- Montar los tornillos 18 y apretarlos a 10 Nm (Loctite 243).

Trabajos posteriores

- Comprobar el funcionamiento del alumbrado.